

# **CAPT-LOCKS**

Super quality Superior products  
International level



Designed according to international standard,  
high quality steel with special treatment, huge stock  
for all series of standard products with nice finishing,  
off-the-shelf sales, immediate delivery.

# CAPT-LOCKS

## Selection Guide of CAPT locks

CAPT-LOCKS is one kind of advanced mechanical basic parts in the international, which are widely used in mechanical joints under every kind of load in the international. During bore-shaft joint, with the twisting force of high-tension bolt, the load transmission is achieved by pressure and friction force produced by the joint face of bore and shaft. It is one kind of joint device without any key.

Joint with CAPT-LOCKS is a new manner of joint with high techniques, which is widely used in many important transmission mechanisms. It has many unique advantages and characters comparing with the traditional mechanical joint.

1. Using CAPT-LOCKS, the manufacturing precision of the joint parts can be reduced. There is no need to over-consider the interference and clearance, so the production cost can be greatly reduced.
2. The installation is very convenient without being heated or any pressure equipment. So long as twisting the bolts tightly as per stipulated procedures and torque, the relevant joint parts can be installed firmly. As for dismounting, the joint states can be relieved as long as the tightening screws are loosed and unloading screws are used. In doing this, CAPT-Locks can be separated with joint parts.
3. Jointing with CAPT-LOCKS is precision without clearance and no-keyway mechanical joint. It has the advantages of high precision, high efficient transmitting, long life time, corrosion-proof and so on. They can bear heavy load and will not be worn or torn during work. They are suitable for every kind of high precision transmission mechanisms.
4. When CAPT-LOCKS are installed in axial way, their location dimension and other parts phase position angle can be adjusted at will without any axial fixing device.
5. CAPT-LOCKS are mechanical device joint by pressure and friction force. While running under overload, they can protect the equipment from breakdown.
6. CAPT-LOCKS can work under the temperature  $-30^{\circ}$  to  $200^{\circ}$ . Many different materials can be chosen for production according to environments and medium surrounded.

There are eight series of CAPT locks produced by Shijiazhuang Sprocket General Factory. They are B, E, D, F(E,A,B), SD HL, ML SK and T. Each series has its own features and operation requirements. It is very important to select a suitable one according to the conditions of usage. The detailed selecting methods are introduced in the instructions for each series of products, Please select according to the following essential factors:

- |                                      |   |
|--------------------------------------|---|
| 1. The needed shaft diameter         | First, make sure for the shaft diameter on which the CAPT Locks are installed. Different series of products are suitable for different scope of shaft diameter.   |
| 2. Transmitting torque               | One should select CAPT locks according to the maximum transmitting torque of the mechanical structure. There are great differences in transmitting torque for different series of CAPT locks.   |
| 3. Axial load of shaft               | When selecting the CAPT locks, axial load must be taken into consideration besides the transmitting torque.   |
| 4. Safety load                       | When selecting the matched shaft and hub, we must pay attention that the maximum axial safety load is bigger than transmitting torque and axial load, in order to ensure that the minimum cross section of the shaft or cannon can transmit the assigned torque safely.   |
| 5. Hub                               | Hard pressure will be made to hub when CAPT lock is installed. It is very important to select the material which have full resistance to pressure and so as to the dimension of the wall of hub. The outside diameter of hub should be designed according to different series of CAPT locks to ensure that the minimum axial cross section can bear the specified radial load.                    |
| 6. Designation assurance coefficient | The rated transmitting torque $M_t$ and axial load $F_t$ in the catalogue of CAPT locks are listed according to the maximum value that can be transmitted by CAPT locks and designation for assurance coefficient haven't been taken into consideration. One must consider start impact load according to the conditions and situations surrounded, then select and design assurance coefficient. |
| 7. Environment surrounded            | If CAPT locks will be used, environmental temperature, humidity, corrosiveness and other factors should be investigated in order to decide the type of CAPT locks and material used.  |

# CAPT-LOCKS

## Catalogue

### General introduction



# CAPT-LOCKS

## B CAPT-LOCKS

Suitable shaft diameter:f19-f1000 (mm)

Rated transmitting torque:0.27-2000KN.M

B CAPT-LOCKS are standard universal CAPT locks. They can be easily and be self-centered installed and can be used for super-big shafts with diameter of 1000 (mm). The material can be carbon steel or stainless steel.



## E CAPT-LOCKS

Suitable shaft diameter:f10-f180 (mm)

Rated transmitting torque:0.007-18.30KN.M

The construction of E type CAPT LOCKS is the compactest and the production cost is very low. During the usage of E CAPT-LOCKS there is no need to use balancing transmitting parts, but they must be compressed for a tight joint by F type or H type tightening flange.

## D CAPT-LOCKS

Suitable shaft diameter: f45-f600 (mm)

Rated transmitting torque:3.90-930KN.M

D CAPT-LOCKS is the heavier type of B CAPT-LOCKS. The transmitting power is two or three times of B type CAPT-Locks. They can be easily self-centered installed.



## F CAPT-LOCKS

Suitable shaft diameter:f14-f400 (mm)

Rated transmitting torque:0.127-355KN.M

F CAPT-LOCKS are the simple type of B CAPT-LOCKS. They are divided into three types, FE, FA and FB. There is only a little difference for the three types in different situations while using. F CAPT-LOCKS can be self-centered installed.

# CAPT-LOCKS

## SD (A,B,C)CAPT-LOCKS

Suitable shaft diameter:f24-f300 (mm)

Rated transmitting torque:0.205-277KN.M

SD CAPT-LOCKS belong to the series for outward installed. They can be used for big shaft diameter to transmit big torque and are especially suitable for cannon.



## HL,HLL CAPT-LOCKS

Suitable shaft diameter:f14-f70 (mm)

Rated transmitting torque:0.038-1.24KN.M

HL CAPT-LOCKS are suitable for small shaft diameter and can be installed with only one nut. The installation is very convenient with very short time. They can be self-centered installed.

## SK CAPT-LOCKS

Suitable shaft diameter:f15-f110 (mm)

Rated transmitting torque:0.126-7.20KN.M

SK CAPT-LOCKS are the heavier type of SD. They are suitable for joint shafts and can transmit bigger torque. They can replace coupling in some power transmission.



## T CAPT-LOCKS

Suitable shaft diameter:f6-f130 (mm)

Rated transmitting torque:0.012-25KN.M

T CAPT-LOCKS are suitable for small shaft diameter and have the functions of sealing, dustproof and waterproof. They have simple structure and can be self-centered installed.

# CAPT-LOCKS

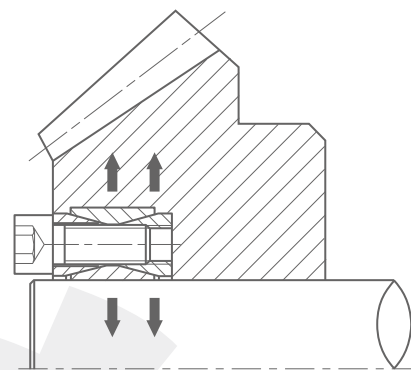

Suit for shaft f19~f300 (mm)



B CAPT-LOCKS, standard commonly used type. The machining precision of the connected parts can be reduced if this type CAPT-LOCKS is used, then reduce the machining cost. Using B type CAPT-LOCKS, easy-on, easy-off, excellent installation and can be self-centered. The connection function depend on its impacted power and frictional power among the CAPT-LOCKS, the bore of hub and the shaft to achieve non-clearance joint and no key will be used, so that some overlaborate work such as key machining, pressing installation and hot installation etc. can be saved, the working efficiency and the lifetime of the machining parts can be raised.

Nomenclature for CAPT-LOCK type B

CL 60 X 90 B

CAPT LOCK type B

out diameter D

bore diameter d

enterprise code  
CAPT-LOCKS

**B** CAPT-LOCKS

# CAPT-LOCKS

## B

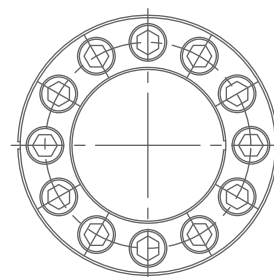
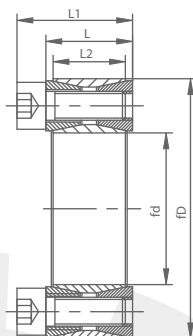
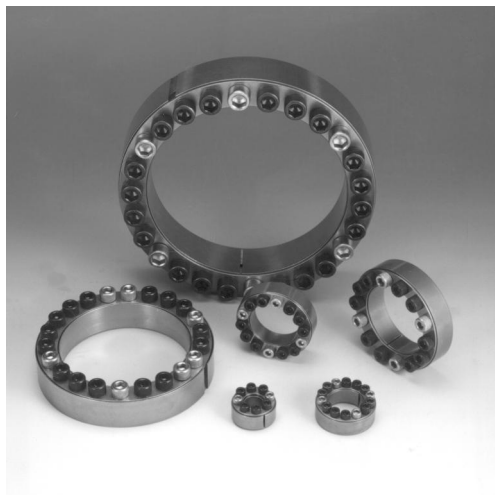

## B CAPT-LOCKS®

Table:1

Catalog dxD	Fundamental dimensions			SizesxN	Rated load		Ps Mpa	Ph Mpa	Ma N.m	G Kg
	L2	L	L1		Ft(Kn)	Mt(Kn.m)				
CL19x47B	17	20	26	M6x8	27	0.24	213	90	14	0.25
CL20x47B	17	20	26	M6x8	27	0.27	210	90	14	0.24
CL22x47B	17	20	26	M6x8	27	0.30	195	90	14	0.23
CL25x50B	17	20	26	M6x9	30	0.38	190	95	14	0.25
CL28x55B	17	20	26	M6x10	33	0.47	185	95	14	0.30
CL30x55B	17	20	26	M6x10	33	0.50	175	95	14	0.29
CL35x60B	17	20	26	M6x12	40	0.70	180	105	14	0.32
CL38x63B	17	20	26	M6x14	46	0.88	185	105	14	0.33
CL40x65B	17	20	26	M6x14	46	0.92	180	110	14	0.34
CL42x72B	20	24	32	M8x12	65	1.36	200	117	35	0.48
CL45x75B	20	24	32	M8x12	72	1.62	210	125	35	0.57
CL50x80B	20	24	32	M8x12	71	1.77	190	115	35	0.60
CL55x85B	20	24	32	M8x14	83	2.27	200	130	35	0.63
CL60x90B	20	24	32	M8x14	83	2.47	180	120	35	0.69
CL65x95B	20	24	32	M8x16	93	3.04	190	130	35	0.73
CL70x110B	24	28	38	M10x14	132	4.60	210	130	70	1.26
CL75x115B	24	28	38	M10x14	131	4.90	195	125	70	1.33
CL80x120B	24	28	38	M10x14	131	5.20	180	120	70	1.40
CL85x125B	24	28	38	M10x16	148	6.30	195	130	70	1.49
CL90x130B	24	28	38	M10x16	147	6.60	180	125	70	1.53
CL95x135B	24	28	38	M10x18	167	7.90	195	135	70	1.62
CL100x145B	29	33	45	M12x14	192	9.60	195	135	125	2.01
CL105x150B	29	33	45	M12x14	190	9.98	185	130	125	2.10
CL110x155B	29	33	45	M12x14	191	10.50	180	125	125	2.15
CL120x165B	29	33	45	M12x14	218	13.10	185	135	125	2.35
CL125x170B	29	33	45	M12x18	220	13.78	180	130	125	2.95
CL130x180B	34	38	50	M12x20	272	17.60	165	120	125	3.51
CL140x190B	34	38	50	M12x22	298	20.90	165	125	125	3.85
CL150x200B	34	38	50	M12x24	324	24.20	170	125	125	4.07
CL160x210B	34	38	50	M12x26	350	28.00	170	130	125	4.30
CL170x225B	38	44	58	M14x22	386	32.80	160	120	190	5.78
CL180x235B	38	44	58	M14x24	420	37.80	165	125	190	6.05
CL190x250B	46	52	66	M14x28	490	46.50	150	115	190	8.25
CL200x260B	46	52	66	M14x30	525	52.50	150	115	190	8.65
CL210x275B	50	56	72	M16x24	599	62.89	151	115	295	10.10

# CAPT-LOCKS

# B

## B CAPT-LOCKS®

Table:2

Catalog dxD	Fundamental dimensions			SizesxN	Rated load		Ps Mpa	Ph Mpa	Ma N.m	G Kg
	L2	L	L1		Ft(Kn)	Mt(Kn.m)				
CL220x285B	50	56	72	M16x26	620	68.00	150	115	295	11.22
CL240x305B	50	56	72	M16x30	715	85.50	160	125	295	12.20
CL250x315B	50	56	72	M16x32	768	96.00	162	125	295	12.70
CL260x325B	50	56	72	M16x34	800	104.00	165	130	295	13.20
CL280x355B	60	66	84	M18x32	915	128.00	145	115	405	19.20
CL300x375B	60	66	84	M18x36	1020	153.00	150	120	405	20.50
CL320x405B	72	78	98	M20x36	1310	210.00	150	120	580	29.60
CL340x425B	72	78	98	M20x36	1310	224.00	145	115	580	31.10
CL360x455B	84	90	112	M22x36	1630	294.00	145	115	780	42.20
CL380x475B	84	90	112	M22x36	1620	308.00	135	110	780	44.00
CL400x495B	84	90	112	M22x36	1610	322.00	130	105	780	46.00
CL420x515B	84	90	112	M22x40	1780	374.00	135	110	780	50.00
CL450x555B	96	102	126	M24x40	2050	461.25	124	100	1000	65.00
CL480x585B	96	102	126	M24x42	2160	518.40	124	100	1000	71.00
CL500x605B	96	102	126	M24x44	2240	560.00	123	100	1000	72.60
CL530x640B	96	102	126	M24x45	2330	617.00	121	110	1000	83.60
CL560x670B	96	102	126	M24x48	2440	680.00	120	110	1000	85.00
CL600x710B	96	102	126	M24x50	2580	775.00	118	100	1000	91.00
CL630x740B	96	102	126	M24x52	2680	844.00	117	105	1000	94.00
CL670x780B	96	102	126	M24x56	2820	944.00	116	100	1000	101.0
CL710x820B	96	102	126	M24x60	2970	1054.0	115	100	1000	106.0
CL750x860B	96	102	126	M24x62	3130	1173.0	115	100	1000	112.0
CL800x910B	96	102	126	M24x66	3260	1300.0	112	100	1000	118.0
CL850x960B	96	102	126	M24x70	3500	1487.0	113	100	1000	125.0
CL900x1010B	96	102	126	M24x75	3680	1650.0	112	100	1000	132.0
CL950x1060B	96	102	126	M24x80	3870	1838.0	112	100	1000	139.0
CL1000x1110B	96	102	126	M24x82	4000	2000.0	110	100	1000	146.0

The items in table 1 are standard products in stock . The items in table 2 will be produced against orders.

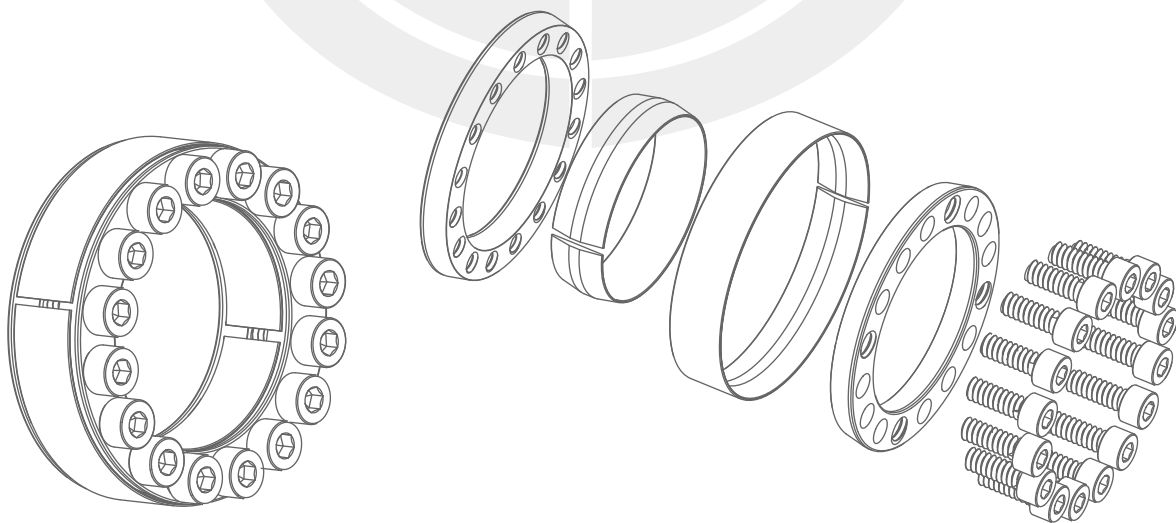



# CAPT-LOCKS

# BH

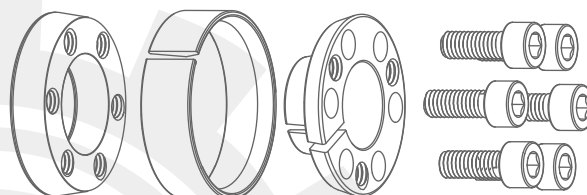
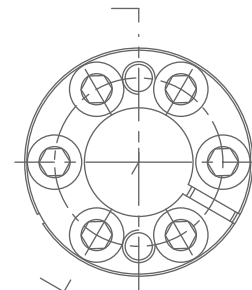
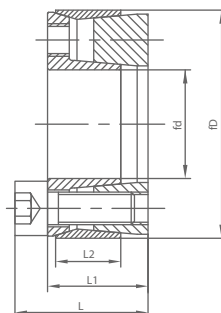

## BH CAPT-LOCKS®

Catalog	Fundamental dimensions			SizesxN	Rated loadPs		Ph	Ma	G	
	dxD	L	L1		L2	Mt(Kn.m)				
CL16x32BH	21.5	17.5	11	M4x4	0.08	9	150	75	5	0.07
CL18x40BH	24.5	18.5	12	M6x5	0.21	23	260	115	17	0.123
CL19x41BH	24.5	18.5	12	M6x5	0.22	23	255	115	17	0.123
CL20x42BH	24.5	18.5	12	M6x6	0.24	25.5	280	130	17	0.13
CL22x44BH	24.5	18.5	12	M6x6	0.26	25.5	260	130	17	0.14
CL24x46BH	24.5	18.5	12	M6x6	0.31	25.5	230	120	17	0.15
CL25x47BH	24.5	18.5	12	M6x6	0.33	25.5	230	120	17	0.16
CL28x50BH	24.5	18.5	12	M6x8	0.49	35	270	150	17	0.17
CL30x52BH	24.5	18.5	12	M6x8	0.53	35	250	140	17	0.18
CL32x54BH	24.5	18.5	12	M6x8	0.56	35	230	130	17	0.19
CL35x57BH	28	22	15	M6x9	0.68	38	200	120	17	0.25
CL36x58BH	28	22	15	M6x9	0.71	38	190	115	17	0.25
CL38x60BH	28	22	15	M6x10	0.83	43.5	200	125	17	0.26
CL40x62BH	28	22	15	M6x10	0.87	43.5	190	120	17	0.27
CL42x70BH	36	28	18	M8x8	1.36	64	225	135	41	0.51
CL45x73BH	36	28	18	M8x8	1.45	64	210	130	41	0.52
CL48x76BH	36	28	18	M8x8	1.55	64	195	125	41	0.55
CL50x78BH	36	28	18	M8x8	1.61	64	190	120	41	0.57
CL55x83BH	36	28	18	M8x9	2.01	72.5	195	130	41	0.63
CL56x84BH	36	28	18	M8x9	2.03	72.5	190	125	41	0.63
CL60x88BH	36	28	18	M8x10	2.42	80.5	195	135	41	0.65
CL63x91BH	36	28	18	M8x10	2.54	80.5	190	130	41	0.68
CL65x93BH	36	28	18	M8x10	2.62	80.5	180	125	41	0.69
CL70x105BH	45	35	22	M10x9	4.02	114	200	130	83	1.20
CL75x110BH	45	35	22	M10x10	4.81	128	205	135	83	1.26
CL80x115BH	45	35	22	M10x10	5.12	128	190	130	83	1.35
CL85x120BH	45	35	22	M10x10	5.45	128	180	125	83	1.40
CL90x125BH	45	35	22	M10x12	6.91	153	205	155	83	1.46
CL100x138BH	45	35	22	M10x12	8.26	168	159	115	83	1.75

## Key elements for designing and calculation B

1. Determine max torque needed and max axial load

$$Mt_{max} = \frac{30000H}{p \cdot n} \cdot K \text{ (N m)}$$

$$Ft_{max} = Ft \cdot K$$

H--Transmission power KW

n--rotational speed r/min

K--coefficient needed

Sheet for coefficient needed, K

No shock load, transmitting with little inertia	1.5 - 2.5
Slight shock load, transmitting with middle inertia	2.0 - 4.0
Big shock load, transmitting with heavy inertia	3.0 - 5.0

2. Calculate synthetic load and transmitted torque

$$M = \sqrt{Mt^2 - \left(\frac{d}{2} \cdot Ft\right)^2}$$

M--Required transmitted torque N.M

Mt--CAPT lock rated transmitted torque N.m

Ft--Rated axial force N

d--Transmission shaft diameter mm

Mt > M, can be used.

Mt < M, need bigger type of CAPT lock or to be installed by two CAPT locks or more together

3. Calculation for the hub diameter

$$Da \geq D \sqrt{\frac{\sigma_b + Ka \cdot Ph}{\sigma_b - Ka \cdot Ph}}$$

Da--outside diameter of hub mm

D--inside diameter of hub mm

Ph--surface pressures on hub Mpa

$\sigma_b$ --tensile strength of material

Ka--It should be 0.6 for single CAPT lock, it will be 0.8 when two CAPT locks or more are installed together

4. Calculation for the inside diameter of cannon

$$dB \leq d \sqrt{\frac{\sigma_b - 2 \times Ps \cdot K3}{\sigma_b}}$$

dB--inside diameter of cannon mm

d--outside diameter of cannon mm

$\sigma_b$ --tensile strength of shaft material Mpa

Ps--pressure on the surface of shaft Mpa

K3--coefficient=0.6

5. Settlement for the surface roughness and dimension tolerance

Fitting section	Ra(um) Surface roughness	Dimension precision
Shaft diameter d	1.6/	h8 - H9
Bore diameter D	1.6/	H8 - H9

6. Installation for CAPT-LOCKS

Cleaning the CAPT-LOCKS, then install it into corresponding position of hub and shaft(Ref Drawing A). Then acc. to the order in Drawing B. Tighten the bolts in turn, the bolts should be tightened step by step in 3 to 4 times up to specified rated torque.

After correct installation, CAPT-LOCKS should be inspected radial and axial runout as per A 0.05mm B 0.002Rmn.

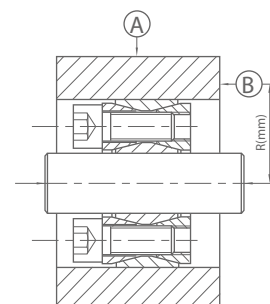
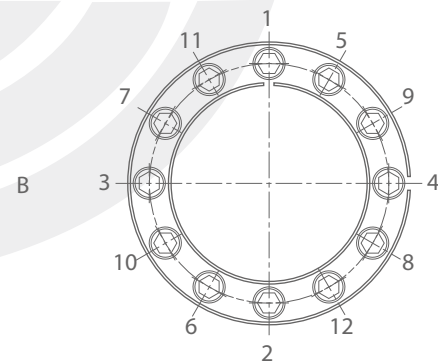
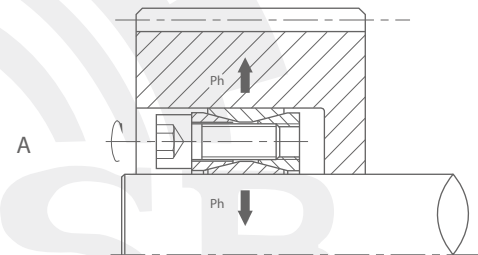

7 Disassembling CAPT-LOCKS

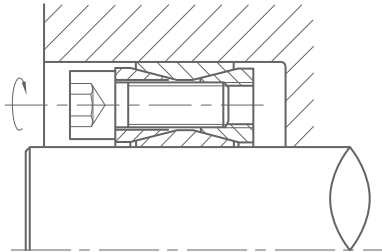

Loose and remove the tightening bolts

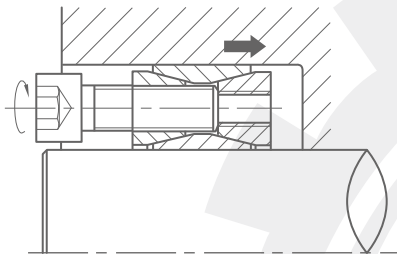

Put bolts into the corresponding threaded jack holes, turning the bolts in clockwise, loose the inner taper rings.

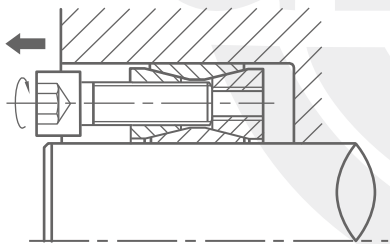

Pull out the bolts with strength, loose and remove outer taper rings

As for disassembling loose and remove all the tightening bolts first, then place the unloading bolts in the corresponding unloading tap holes (ie, tap holes with bolts zinc plated),and tighten them in turn, taper rings on the both side of CAPT lock can be gradually seperated. By doing so, the inner and outer rings will counter spring out from the bore of hub and surface of shaft. Then the CAPT lock can be disassembled.

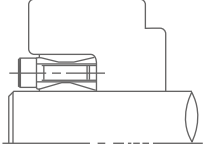
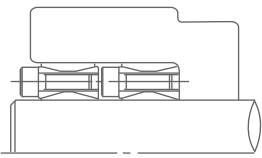
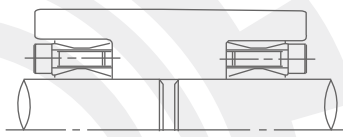
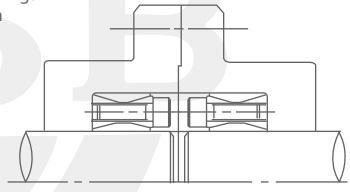
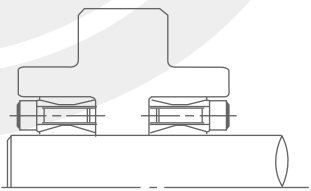
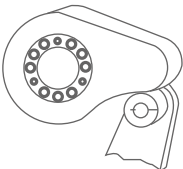
 <p>Conventional installation, for the usage of ordinary situation and general power transmission.</p>
<p>Used in pairs, for the usage of greater power transmission</p> 
<p>Mounted with shaft sleeves to connect transmission between two shafts. They have the same function with couplings.</p> 
<p>Mounted with the couplings to connect transmission between two shafts</p> 
<p>Installed from both sides, for the usage of greater power transmission</p> 
<p>While installed with cams, the position and anger of the cams can be adjusted at will</p> 

# CAPT-LOCKS

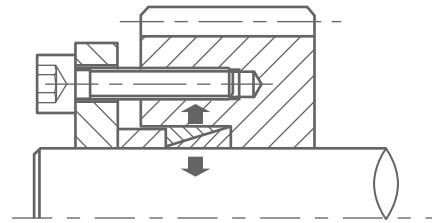

suit for shaft f10~f150 (mm)

E CAPT-LOCKS include two inner and outer taper rings, the structure is both simple and compact. It needn't big installation space, completely circular without split and with good dynamic balance property.

E CAPT-LOCKS bring the high surface pressures on shaft by the pressing flange, compress the shaft and the hub hole tightly to achieve the connection of them. It can seal the shaft surface and inner hole and obtain good results. It is applicable to the light load, small space installation occasion.

According to the different shaft diameter and structure, there are F type pressing flange and H type pressing flange for your choosing.

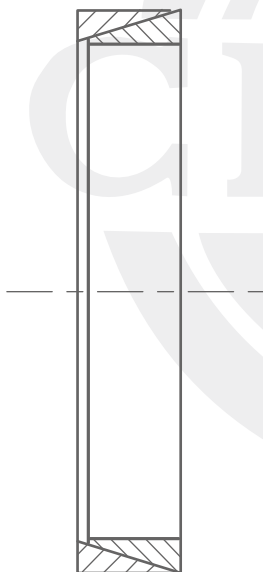

Nomenclature for CAPT-LOCK type E

CL 36 X 42 E

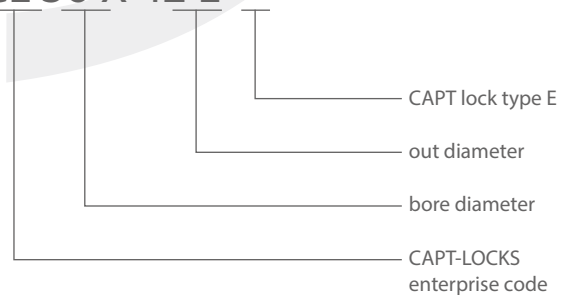

## E CAPT-LOCKS

# CAPT-LOCKS

# E

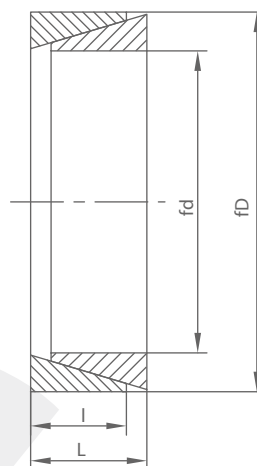

## E CAPT-LOCKS®

Catalog	Fundamental dimensions		Rated load				Ps	Ph	G	kg
	dxD	L	l	Fo(Kn)	Fe(Kn)	Mt(Kn.m)	Ft(Kn)	Mpa	Mpa	
CL10x13E	4.5	3.7	5.9	6.2	0.007	1.4	98	75	0.002	
CL12x15E	4.5	3.7	5.0	7.4	0.010	1.67	98	78	0.002	
CL13x16E	4.5	3.7	4.7	8.0	0.012	1.8	98	79	0.002	
CL14x18E	6.3	5.3	8.1	12.3	0.020	2.8	98	76	0.005	
CL15x19E	6.3	5.3	10.3	13.2	0.023	3.0	98	77	0.005	
CL16x20E	6.3	5.3	9.8	14.1	0.025	3.2	98	78	0.006	
CL17x21E	6.3	5.3	9.2	15.0	0.028	3.4	98	79	0.006	
CL18x22E	6.3	5.3	8.9	15.9	0.032	3.6	98	80	0.008	
CL19x24E	6.3	5.3	12.3	16.8	0.036	3.8	98	77	0.008	
CL20x25E	6.3	5.3	11.9	17.6	0.039	4.0	98	78	0.01	
CL22x26E	6.3	5.3	8.9	19.4	0.047	4.4	98	83	0.01	
CL24x28E	6.3	5.3	8.2	21.2	0.057	4.8	98	84	0.01	
CL25x30E	6.3	5.3	9.7	22.1	0.061	5.0	98	81	0.01	
CL28x32E	6.3	5.3	7.2	24.7	0.076	5.6	98	86	0.01	
CL30x35E	6.3	5.3	8.3	26.5	0.088	6.0	98	84	0.01	
CL32x36E	6.3	5.3	7.7	28.2	0.102	6.3	98	87	0.015	
CL35x40E	7	6	9.9	34.9	0.137	7.9	98	86	0.02	
CL36x42E	7	6	11.4	35.9	0.145	8.1	98	84	0.02	
CL38x44E	7	6	10.9	37.9	0.163	8.6	98	84	0.02	
CL40x45E	8	6.6	13.5	44.1	0.201	9.9	98	87	0.025	
CL42x48E	8	6.6	15.3	46.1	0.220	10.5	98	86	0.04	
CL45x52E	10	8.6	25.6	64.7	0.321	14.6	98	85	0.043	
CL48x55E	10	8.6	24.1	68.6	0.378	15.6	98	85	0.045	
CL50x57E	10	8.6	23.2	71.5	0.401	16.2	98	86	0.05	
CL55x62E	10	8.6	21.3	78.4	0.481	17.8	98	87	0.06	
CL56x64E	12	10.4	28.6	97.0	0.620	21.7	98	86	0.074	
CL60x68E	12	10.4	26.9	104	0.701	23.5	98	87	0.074	
CL63x71E	12	10.4	25.6	109	0.780	24.5	98	87	0.08	
CL65x73E	12	10.4	24.9	113	0.813	25.3	98	87	0.08	
CL70x79E	14	12.2	30.4	142	1.121	32.0	98	87	0.11	
CL71x80E	14	12.2	30.0	144	1.151	32.3	98	87	0.12	
CL75x84E	14	12.2	33.7	152	1.268	34.2	98	86	0.12	
CL80x91E	17	15	47.1	200	1.772	45	98	86	0.19	
CL85x96E	17	15	44.6	212	2.021	48	98	87	0.20	
CL90x101E	17	15	42.2	224	2.252	51	98	88	0.22	
CL95x106E	17	15	40.1	237	2.530	53	98	86	0.23	
CL100x114E	21	18.7	59.8	311	3.453	70	98	87	0.38	

# CAPT-LOCKS

# E

## E CAPT-LOCKS <sup>®</sup>

Catalog	Fundamental dimensions		Rated load			Ps	Ph	G	kg
	dxD	L	I	Fo(Kn)	Fe(Kn)	Mt(Kn.m)	Ft(Kn)	Mpa	
CL105x119E	21	18.7	57.6	323	3.82	73.2	98	87	0.40
CL110x124E	21	18.7	64.1	342	4.17	76.5	98	87	0.41
CL120x134E	21	18.7	59.0	373	4.98	83.5	98	88	0.45
CL125x139E	21	18.7	63.0	432	5.75	92	98	87	0.62
CL130x148E	28	25.3	93.8	547	7.85	123	98	86	0.85
CL140x158E	28	25.3	87.5	589	9.15	132	98	87	0.91
CL150x168E	28	25.3	82.0	631	10.6	141	98	87	0.97
CL160x178E	28	25.3	79.0	742	12.2	153	98	86	1.02
CL170x191E	33	30.0	83.0	830	16.3	192	98	86	1.50
CL180x201E	33	30.0	75.3	850	18.3	204	98	87	1.58

## E CAPT-LOCKS Assembling diagram:

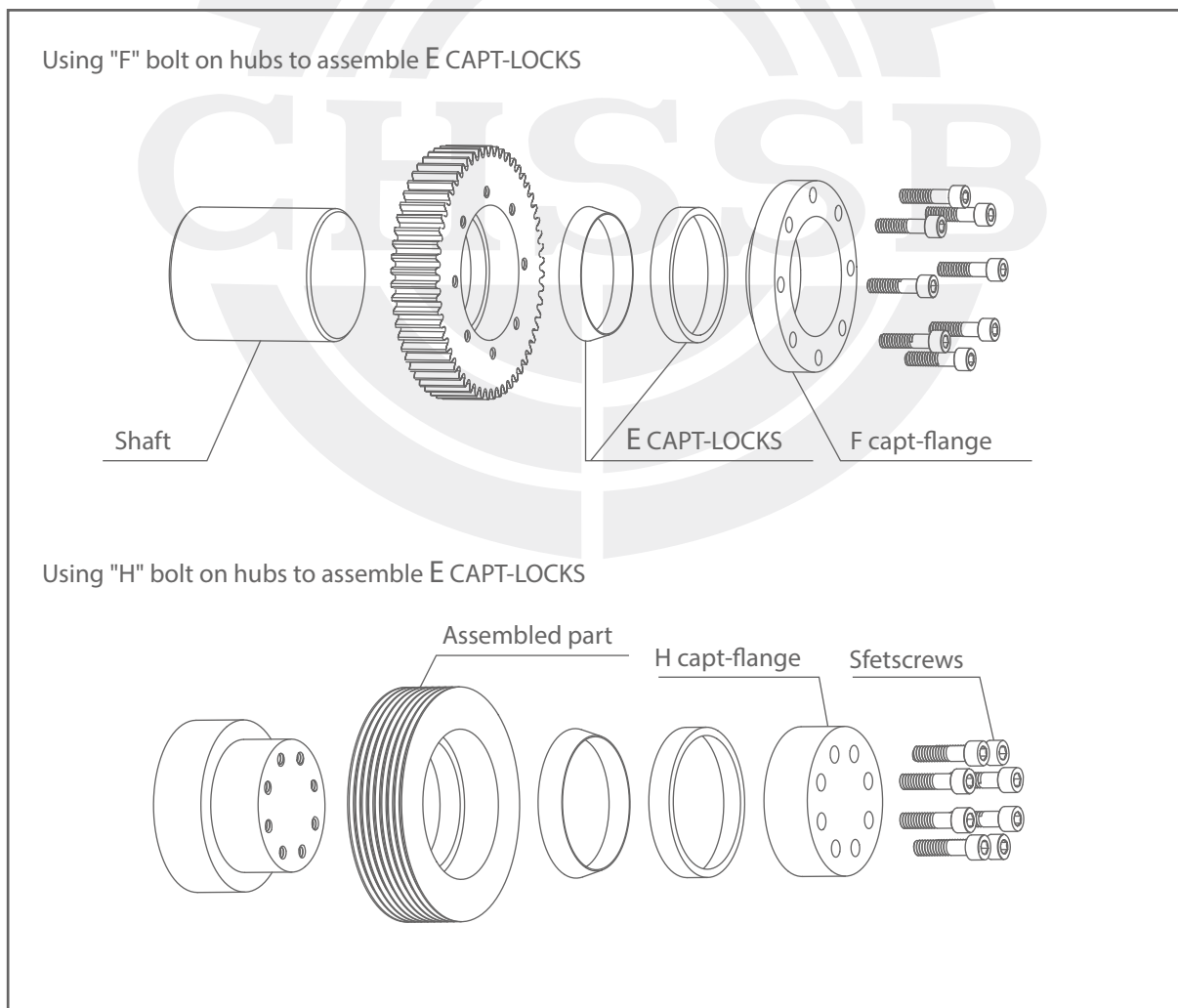

# CAPT-LOCKS

## F Tightening Flange Type F

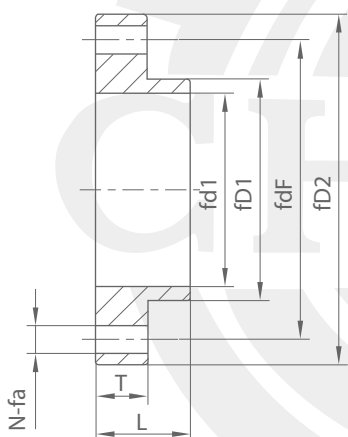

F CAPT-FLANGE

**F 36 X 42**

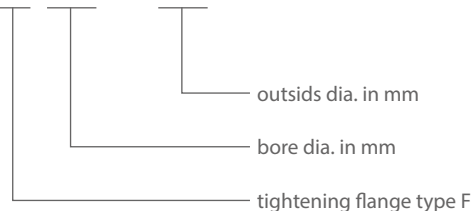

Catalog	fundamental dimensions							G (kg)
	dxD	d1	D1	dF	D2	T	L	
F10x13	10.2	12.8	28	36	8	13	4.4	0.06
F12x15	12.2	14.8	28	36	8	13	4.4	0.06
F13x16	13.2	15.8	28	36	8	13	4.4	0.06
F14x18	14.2	17.8	35	45	10	18	5.5	0.12
F15x19	15.2	18.8	35	45	10	18	5.5	0.12
F16x20	16.2	19.8	35	45	10	18	5.5	0.12
F17x21	17.2	20.8	35	45	10	18	5.5	0.12
F18x22	18.2	21.8	35	45	10	18	5.5	0.12
F19x24	19.2	23.8	40	50	10	18	5.5	0.14
F20x25	20.2	24.8	40	50	10	18	5.5	0.14
F22x26	22.2	25.8	40	50	10	18	5.5	0.14
F24x28	24.2	27.8	45	55	10	18	5.5	0.16
F25x30	25.2	29.8	45	55	10	18	5.5	0.16
F28x32	28.2	31.8	45	55	10	18	5.5	0.17
F30x35	30.2	34.8	50	60	10	18	5.5	0.18
F32x36	32.2	35.8	50	60	10	18	5.5	0.19
F35x40	35.2	39.8	58	68	10	18	5.5	0.23
F36x42	36.2	41.8	58	68	10	18	5.5	0.23
F38x44	38.2	43.8	58	68	10	18	5.5	0.27
F40x45	40.2	44.8	62	74	12	22	6.6	0.31
F42x48	42.2	47.8	62	74	12	22	6.6	0.35
F45x52	45.2	51.8	70	82	12	22	6.6	0.36
F48x55	48.2	54.8	70	82	12	22	6.6	0.37
F50x57	50.2	56.8	70	82	12	22	6.6	0.38
F55x62	55.2	61.8	78	90	12	22	6.6	0.42
F56x64	56.2	63.8	86	102	16	26	8.8	0.73
F60x68	60.2	67.8	86	102	16	26	8.8	0.77
F63x71	63.2	70.8	92	108	16	26	8.8	0.82
F65x73	65.2	72.8	92	108	16	26	8.8	0.85
F70x79	70.3	78.7	98	114	16	28	8.8	0.89
F71x80	71.3	79.7	98	114	16	28	8.8	0.90
F75x84	75.3	83.7	104	120	16	28	8.8	0.96
F80x91	80.3	90.7	110	130	20	32	11	1.42
F85x96	85.3	95.7	116	136	20	32	11	1.53
F90x101	90.3	100.7	120	140	20	32	11	1.56
F95x106	95.3	105.7	126	146	20	32	11	1.67
F100x114	100.3	113.7	134	154	20	32	11	1.90
F105x119	105.3	118.7	141	165	24	40	13	2.05
F110x124	110.3	123.7	146	170	24	40	13	2.15
F120x134	120.4	133.6	156	180	24	40	13	2.5
F125x139	125.4	138.6	175	203	28	46	15.2	2.68
F130x148	130.4	147.6	186	214	28	46	15.2	2.8
F140x158	140.4	157.6	196	224	28	46	15.2	3.15
F150x168	150.4	167.6	206	234	28	46	15.2	3.5
F160x178	160.4	177.6	216	244	28	46	15.2	3.95
F170x191	170.4	190.6	232	264	30	50	17.2	4.5
F180x201	180.4	200.6	242	274	30	50	17.2	5.1

# CAPT-LOCKS

## H Tightening Flange Type H

Catalog	fundamental dimensions						G (kg)	
	dxD	d1	D1	dF	T	L		a
H10x13	10.2	12.8			4	9	8.8	0.04
H12x15	12.2	14.8			4	9	8.8	0.04
H13x16	13.2	15.8			4	9	8.8	0.04
H14x18	14.2	17.8			5	13	11	0.07
H15x19	15.2	18.8			5	13	11	0.07
H16x20	16.2	19.8			5	13	11	0.07
H17x21	17.2	20.8			5	13	11	0.07
H18x22	18.2	21.8			5	13	11	0.07
H19x24	19.2	23.8			7	15	13	0.09
H20x25	20.2	24.8			7	15	13	0.09
H22x26	22.2	25.8			7	15	13	0.10
H24x28	24.2	27.8	11	10	18	5.5	0.10	
H25x30	25.2	29.8	12	10	18	5.5	0.11	
H28x32	28.2	31.8	14	12	20	6.6	0.12	
H30x35	30.2	34.8	16	12	20	6.6	0.12	
H32x36	32.2	35.8	16	12	20	6.6	0.15	
H35x40	35.2	39.8	19	12	20	6.6	0.16	
H36x42	36.2	41.8	20	12	20	6.6	0.18	
H38x44	38.2	43.8	22	12	20	6.6	0.20	
H40x45	40.2	44.8	24	12	22	6.6	0.23	
H42x48	42.2	47.8	26	12	22	6.6	0.23	
H45x52	45.2	51.8	29	12	22	6.6	0.25	
H48x55	48.2	54.8	32	12	22	6.6	0.25	
H50x57	50.2	56.8	34	12	22	6.6	0.27	
H55x62	55.2	61.8	36	12	22	6.6	0.50	
H56x64	56.2	63.8	38	16	26	8.8	0.51	
H60x68	60.2	67.8	42	16	26	8.8	0.53	
H63x71	63.2	70.8	45	16	26	8.8	0.55	
H65x73	65.2	72.8	47	16	26	8.8	0.58	
H70x79	70.3	78.7	50	20	32	11	0.59	
H71x80	71.3	79.7	51	20	32	11	0.63	
H75x84	75.3	83.7	55	20	32	11	0.68	
H80x91	80.3	90.7	60	20	32	11	0.92	
H85x96	85.3	95.7	65	20	32	11	1.0	
H90x101	90.3	100.7	70	20	32	11	1.02	
H95x106	95.3	105.7	75	20	32	11	1.09	
H100x114	100.3	113.7	80	20	32	11	1.24	
H105x119	105.3	118.7	85	24	40	13	1.38	
H110x124	110.3	123.7	88	24	40	13	1.46	
H120x134	120.4	133.6	98	24	40	13	1.63	
H125x139	125.4	138.6	104	28	46	15.4	1.75	
H130x148	130.4	147.6	108	28	46	15.4	1.82	
H140x158	140.4	157.6	118	28	46	15.4	2.05	
H150x168	150.4	167.6	128	28	46	15.4	2.28	
H160x178	160.4	177.6	138	28	46	15.4	2.59	
H170x191	170.4	190.6	148	30	50	17.2	3.10	
H180x201	180.4	200.6	158	30	50	17.2	3.45	

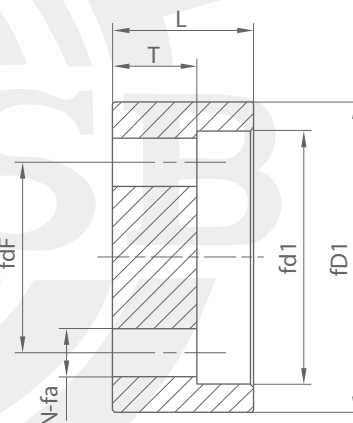

H CAPT-FLANGE

**H 36 X 42**

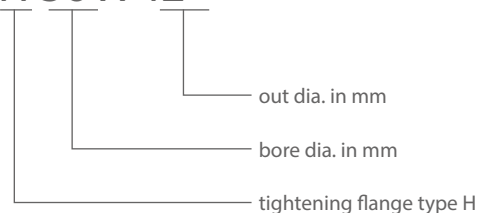



# CAPT-LOCKS

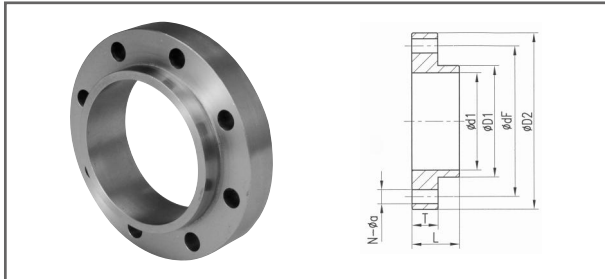

Catalog	internal hexagon headed bolt				
	dF	SIZES	N	Ms (kgf.m)	E (kgf)
F10x13 F12x15 F13x16	28	M4x18		0.39	1680
F14x18 F15x19 F16x20 F17x21 F18x22	35	M5x20	3	0.77	2700
F19x24 F20x25 F22x26	40	M5x20	4	0.77	3600
F24x28 F25x30 F28x32	45				
F30x35 F32x36	50	M5x20	5	0.77	4500
F35x40 F36x42 F38x44	58	M5x20	6	0.77	5400
F40x45 F42x48	62	M6x25		1.3	7620
F45x52 F48x55 F50x57	70	M6x25	8	1.3	10160
F55x62 F56x64	78	M6x25	10	1.3	12700
F60x68 F63x71 F65x73	92	M8x35	8	3.2	18400
F70x79	98				
F71x80 F75x84	104	M8x35	10	3.2	23000
F80x91 F85x96	110	M10x40	8	6.3	29600
F90x101	116				
F95x106 F100x114 F105x119	120	M10x40	9	6.3	33300
F110x124	126				
F120x134	134				
F125x139 F130x148 F140x158	141	M12x50	10	12	75600
F150x168	146				
F160x178	156				
F170x191 F180x201	175	M14x60	10	19	90700
F130x148 F140x158 F150x168 F160x178 F170x191	186				
F170x191 F180x201	216	M16x70	10	30	118800
F170x191 F180x201	232				
F180x201	242				

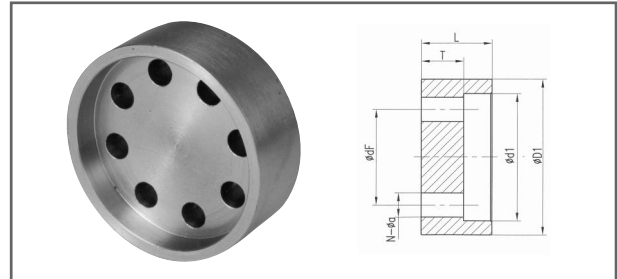

Catalog	internal hexagon headed bolt				
	dF	SIZES	N	Ms (kgf.m)	E (kgf)
F10x13 F12x15 F13x16		M8x30		3.2	2300
F14x18 F15x19 F16x20 F17x21 F18x22		M10x35	1	6.3	3700
F19x24 F20x25 F22x26					
F24x28 F25x30 F28x32	11	M5x20	3	0.77	2700
F30x35 F32x36 F35x40	12				
F36x42 F38x44 F40x45	14				
F42x48 F45x52 F48x55 F50x57	16	M6x25	3	1.3	3810
F55x62 F56x64	19				
F60x68 F63x71 F65x73	20	M6x25	4	.3	5080
F70x79	22				
F71x80 F75x84	24	M6x25	6	1.3	7620
F80x91 F85x96	26				
F90x101 F95x106 F100x114 F105x119	29	M6x25	8	1.3	10160
F110x124 F120x134	32				
F125x139 F130x148 F140x158	34				
F150x168 F160x178 F170x191	36				
F180x201	38				
F60x68 F63x71 F65x73	42	M8x35	6	3.2	13800
F70x79	45				
F71x80 F75x84	47	M8x35	8	3.2	18400
F80x91 F85x96	50				
F90x101 F95x106 F100x114 F105x119	51	M10x40	6	6.3	22200
F110x124 F120x134	55				
F125x139 F130x148 F140x158	60				
F150x168 F160x178 F170x191	65				
F180x201	70				
F90x101 F95x106 F100x114 F105x119	75	M10x40	6	6.3	29600
F110x124 F120x134	75				
F125x139 F130x148 F140x158	80				
F150x168 F160x178 F170x191	85				
F180x201	88				
F90x101 F95x106 F100x114 F105x119	98	M12x50	10	12	75600
F110x124 F120x134	104				
F125x139 F130x148 F140x158	108				
F150x168 F160x178 F170x191	118				
F180x201	128				
F90x101 F95x106 F100x114 F105x119	138	M14x60	10	19	90700
F110x124 F120x134	148				
F125x139 F130x148 F140x158	158				
F150x168 F160x178 F170x191	158				
F180x201	158				
F90x101 F95x106 F100x114 F105x119	148	M16x70	10	30	118800
F110x124 F120x134	148				
F125x139 F130x148 F140x158	148				
F150x168 F160x178 F170x191	148				
F180x201	158				

Note: Tap hole will be in the center of the tightening flange when "√" = 1

### Key elements for designing and calculation

1. the characteristic parameters of CAPT locks E  
 A. the relationship between transmitting torque and axial load, surface pressure.

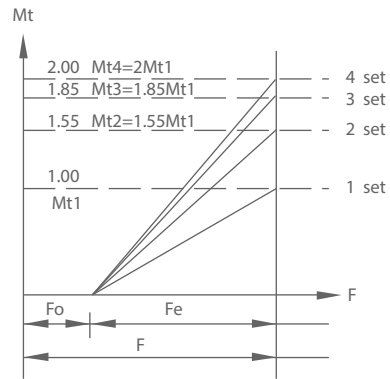
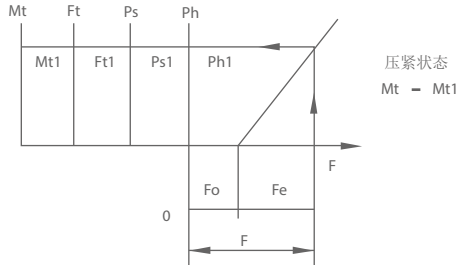

proportion diagram of transmission power when multi-groups of E CAPT are used

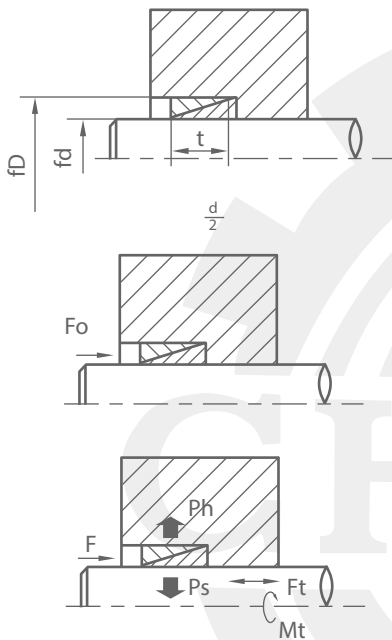

2. Determine the surface roughness and dimension tolerance

Inner diameter d	Tolerance of Shaft diameter	Tolerance of Bore diameter	Surface roughness
10-38	h6	H7	1.6/
40-150	h8	H8	1.6/

3. Determine max torque and max axial load

$$Mt_{max} = \frac{30000H}{p \cdot n} \cdot K \text{ (N.m)}$$

$$Ft_{max} = Ft \cdot K$$

H--Transmission power KW  
 n--rotational speed r/min  
 K--coefficient needed  
 Used coefficient sheet for K

Mt--transmitting power N.m=N.u.--  
 Ft--rated axial force N=N.U=2Mt--  
 Ps,Ph--Pressure on hub Mpa  
 Fo--initial pressure  
 Fe--effective pressure  
 F--the whole pressure

Sheet for coefficient used K

No shock load, transmitting with little inertia	1.5 - 2.5
Slight shock load, transmitting with middle inertia	2.0 - 4.0
Big shock load, transmitting with heavy inertia	3.0 - 5.0

- B. Operational diagram of using multi-groups of E CAPT locks

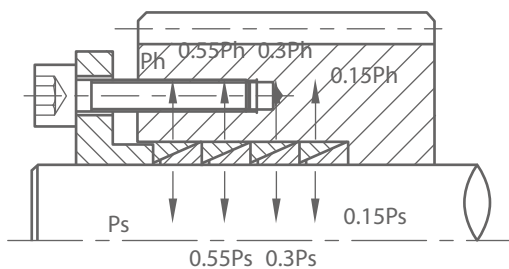

conceptual diagram for how to use multi-groups of E CAPT Locks.

4. Calculate synthetic load and transmitted torque

$$M = \sqrt{Mt^2 - \left(\frac{d}{2} \times Ft\right)^2}$$

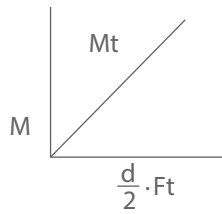

M--Required transmit torque N.M  
 Mt--CAPT lock rated transmitted torque N.m  
 Ft--Rated axial force N  
 d--Transmission shaft diameter mm

5.Determination for thd dimensions of pressing flange

IF  $\geq 2xdG$   
 IB  $\geq 1.5xdG$

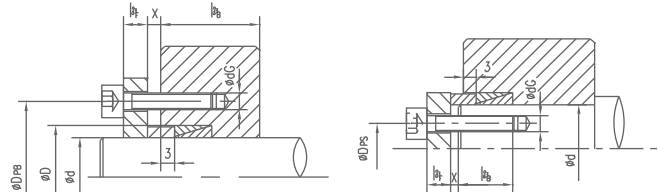

Mt  $\geq$  M, can be used.  
 Mt < M, need bigger type of CAPT lock or to be installed by two CAPT locks or more together

Shaft diameter d=f10-f30(mm)  
 Shaft diameter d=f32-f150(mm)

dpB=D+8+dG  
 dpS=d+8-dG  
 dpB=D+10+dG  
 dps=d-10-dG

Conventional installation of E CAPT-LOCKS

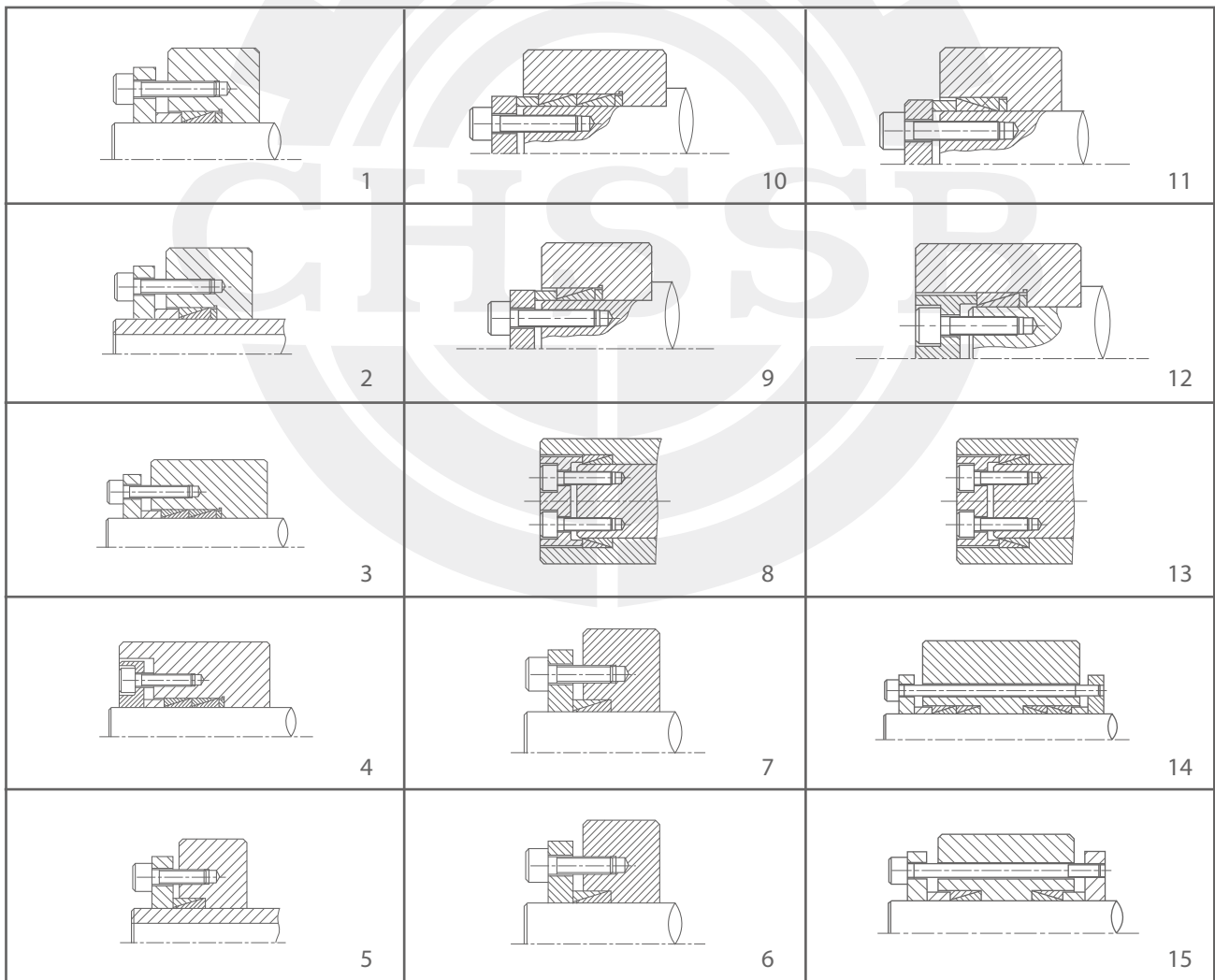

# CAPT-LOCKS

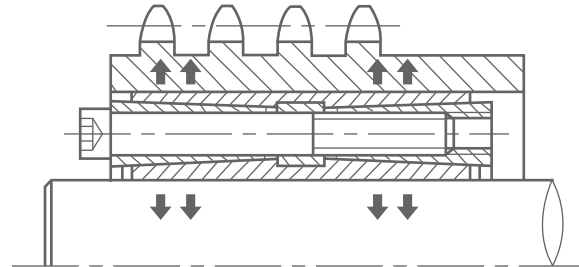

suit for shaft diameter f45~f300 (mm)



D CAPT-LOCKS is a heavier type of B type which connecting capacity is 2 or 3 times of B type and the dimension series of D type CAPT lock is the same as B type so if using 1 piece of D type CAPT locks, the cost can be reduced.

D CAPT-LOCKS has characteristics of self centered installed and good concentricity. The guiding taper surface does not need to be machined specially, the central bore of hub and the surface of shaft all in straight line, then more production time and cost can be saved.

D CAPT-LOCKS have the characteristics of easy on and easy off, high precision for installation and connecting capacity. The connecting function of D CAPT-LOCKS comes from the friction and pressure between the CAPT-LOCKS with shaft and hub, it is the connecting without slot and key. In this way, the processes for machining key, pressing installation, hot charging can be saved. D type can be used in the transmission by connection with a heavy duty and big torque.

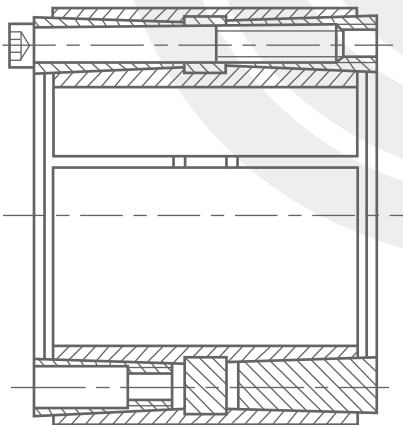

Nomenclature for CAPT-LOCKS type D

CL 200 X 260 D

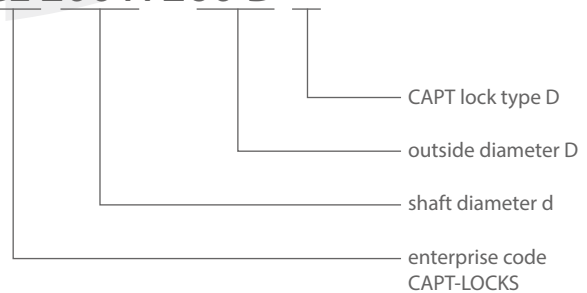

## D CAPT-LOCKS

# CAPT-LOCKS

## D

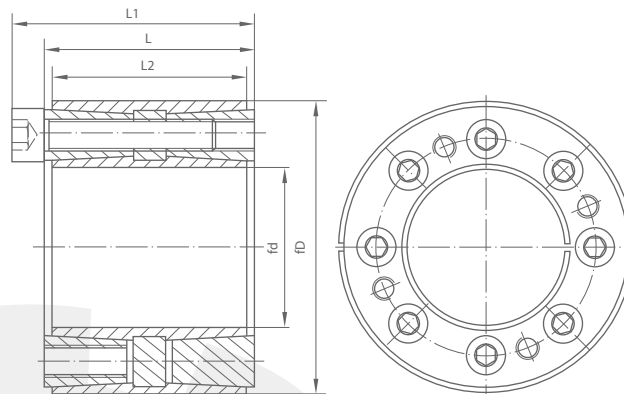

## D CAPT-LOCKS®

Catalog	Fundamental dimensions			SizesxN	Rated load		Ps	Ph	Ma	G
	dxD	L2	L		L1	Ft(Kn)				
CL45x75D	56	64	72	M8x9	160	3.51	179	108	41	1.25
CL48x80D	56	64	72	M8x9	160	3.72	168	101	41	1.41
CL50x80D	56	64	72	M8x9	170	4.3	162	101	41	1.35
CL55x85D	56	64	72	M8x9	170	4.7	147	95	41	1.45
CL60x90D	56	64	72	M8x11	190	5.81	165	110	41	1.55
CL65x95D	56	64	72	M8x11	190	6.10	130	89	41	1.92
CL70x110D	70	78	88	M10x11	330	11.8	179	114	83	3.11
CL75x115D	70	78	88	M10x11	330	12.6	167	109	83	3.28
CL80x120D	70	78	88	M10x12	360	14.7	171	114	83	3.45
CL85x125D	70	78	88	M10x12	360	15.6	161	109	83	3.63
CL90x130D	70	78	88	M10x13	390	17.9	165	114	83	3.8
CL95x135D	70	78	88	M10x13	390	18.9	156	110	83	3.97
CL100x145D	90	100	112	M12x12	467	23.3	181	108	145	6.80
CL110x155D	90	100	112	M12x13	553	30.4	190	110	145	7.50
CL120x165D	90	100	112	M12x15	617	37	195	119	145	8.60
CL130x180D	104	116	130	M14x13	759	49	180	111	230	11.1
CL140x190D	104	116	130	M14x15	843	59	186	121	230	11.8
CL150x200D	104	116	130	M14x16	897	67	185	123	230	12.6
CL160x210D	104	116	130	M14x17	950	76	183	123	230	13.4
CL170x225D	134	146	162	M16x15	1223	104	172	110	355	19.6
CL180x235D	134	146	162	M16x16	1289	116	172	113	355	20.6
CL190x250D	134	146	162	M16x17	1363	130	172	113	355	23.8
CL200x260D	134	146	162	M16x17	1368	136	172	108	355	24.9
CL220x285D	134	146	162	M16x20	1582	174	172	118	355	29.6
CL240x305D	134	146	162	M16x22	1725	207	172	120	355	31.9
CL260x325D	134	146	162	M16x22	1800	225	170	110	355	34.3
CL280x355D	165	177	197	M20x20	2429	340	168	118	690	52.0
CL300x375D	165	177	197	M20x22	2540	381	161	112	690	55.3
CL320x405D	165	177	197	M20x22	2781	431	175	122	690	67.3
CL340x425D	165	177	197	M20x24	2994	509	171	108	690	71.0

The items<CL200X260D are standard products in stock, the items>CL200X260D will be produced against orders

# CAPT-LOCKS

# DS

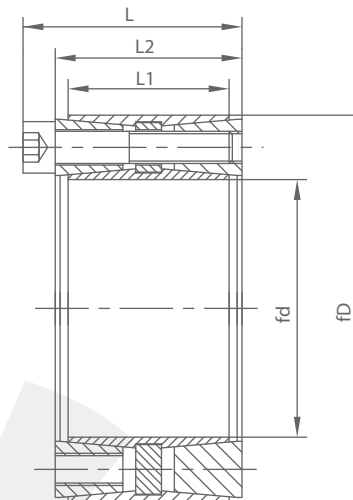

## DS CAPT-LOCKS<sup>®</sup>

Catalog	Fundamental dimensions			SizesxN	Rated load		Ps Mpa	Ph Mpa	Ma N.m	G Kg
	dxD	L1	L2		L	Ft(Kn)				
CL70x110DS	50	58	68	M10x8	5.15	145	112	71	60	2.31
CL75x115DS	50	58	68	M10x9	6.10	163	116	70	60	2.40
CL80x120DS	50	58	68	M10x9	6.55	163	109	68	60	2.51
CL85x125DS	50	58	68	M10x10	7.70	182	114	77	60	2.60
CL90x130DS	50	58	68	M10x10	8.12	182	107	74	60	2.71
CL95x135DS	50	58	68	M10x10	8.60	182	102	72	60	2.80
CL100x145DS	60	70	80	M10x10	9.10	182	80	55	60	4.05
CL110x155DS	60	70	80	M10x10	10.00	182	75	52	60	4.51
CL120x165DS	60	70	80	M10x12	13.10	218	80	59	60	4.85
CL130x180DS	68	80	92	M12x12	20.70	319	95	69	105	6.30
CL140x190DS	68	80	92	M12x12	22.30	319	89	66	105	6.61
CL150x200DS	68	80	92	M12x12	23.90	319	83	62	105	7.02
CL160x210DS	68	80	92	M12x12	29.80	372	90	69	105	7.40
CL170x225DS	75	87	99	M12x16	36.20	426	89	67	105	10.0
CL180x235DS	75	87	99	M12x16	38.30	426	84	64	105	11.3
CL190x250DS	88	100	112	M12x18	45.50	479	76	58	105	14.0
CL200x260DS	88	100	112	M12x18	47.90	479	72	56	105	15.2
CL220x285DS	98	110	124	M14x14	56.20	511	63	49	165	19.5
CL240x305DS	98	110	124	M14x18	78.80	657	74	58	165	21.5
CL260x325DS	98	110	124	M14x20	94.90	730	76	61	165	23.0
CL280x355DS	120	132	148	M16x20	142.0	1015	80	63	260	29.0
CL300x375DS	120	132	148	M16x24	182.0	1218	89	72	260	30.5
CL320x405DS	135	147	163	M16x24	194.0	1218	75	60	260	47.0
CL340x425DS	135	147	163	M16x24	207.0	1218	71	57	260	50.0

# CAPT-LOCKS

# DE

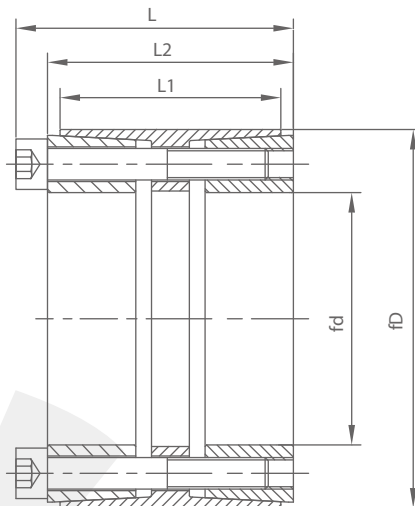
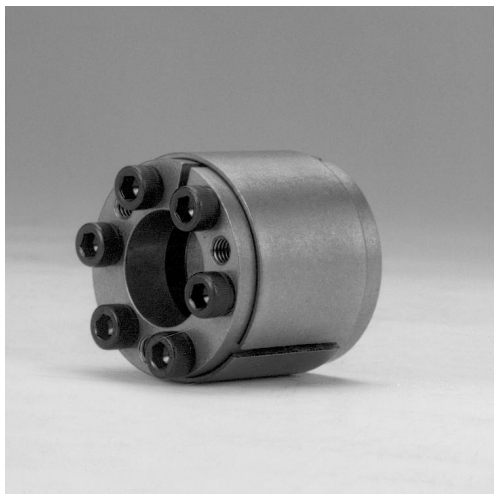

## DE CAPT-LOCKS<sup>®</sup>

Catalog	Fundamental dimensions			SizesxN	Rated load		Ps	Ph	Ma	G
	dxD	L1	L2		L	Ft(Kn)				
CL25x50DE	32	40	46	M6x6	0.73	70	250	97	17	1.28
CL28x55DE	32	40	46	M6x6	0.82	70	220	117	17	1.35
CL30x55DE	32	40	46	M6x6	0.90	70	210	117	17	1.47
CL35x60DE	44	54	60	M6x7	1.22	80	150	107	17	1.55
CL38x65DE	44	54	60	M6x10	2.26	130	240	124	17	1.58
CL40x65DE	44	54	60	M6x10	2.39	130	230	124	17	1.68
CL42x75DE	44	54	62	M8x7	2.51	130	220	120	41	1.76
CL45x75DE	44	54	62	M8x7	2.69	130	200	120	41	1.85
CL48x80DE	56	64	72	M8x8	3.27	150	220	130	41	1.96
CL50x80DE	56	64	72	M8x8	3.41	150	170	130	41	2.04
CL55x85DE	56	64	72	M8x9	4.22	170	170	110	41	2.15
CL60x90DE	56	64	72	M8x10	5.11	180	170	120	41	2.25
CL65x95DE	56	64	72	M8x10	5.54	190	160	110	41	2.39
CL70x110DE	70	78	88	M10x10	10.15	310	200	130	83	2.48
CL75x115DE	70	78	88	M10x10	10.88	320	190	120	83	2.62
CL80x120DE	70	78	88	M10x12	12.76	340	190	130	83	2.76
CL85x125DE	70	78	88	M10x12	14.80	380	200	140	83	2.90
CL90x130DE	70	78	88	M10x12	15.65	380	190	130	83	3.04
CL95x135DE	70	78	88	M10x12	16.53	380	180	130	83	3.17
CL100x145DE	90	100	112	M12x12	23.25	510	180	120	145	5.44
CL110x155DE	90	100	112	M12x12	28.01	530	170	130	145	6.00
CL120x165DE	90	100	112	M12x14	35.51	650	190	140	145	6.88
CL130x180DE	104	116	130	M14x12	45.13	770	180	130	230	8.88
CL140x190DE	104	116	130	M14x14	56.70	870	190	140	230	9.44
CL150x200DE	104	116	130	M14x16	65.10	940	190	140	230	10.08
CL160x210DE	104	116	130	M14x16	74.05	1000	190	150	230	10.72
CL170x225DE	134	148	164	M16x14	95.25	1220	170	130	355	15.68
CL180x235DE	134	148	164	M16x16	108.05	1290	170	130	355	16.48
CL190x250DE	134	148	164	M16x16	121.65	1360	170	130	355	19.04
CL200x260DE	134	148	164	M16x16	128.06	1370	160	130	355	19.92
CL220x265DE	134	148	164	M16x18	158.48	1580	170	130	355	23.68

# CAPT-LOCKS

## D CAPT-Locks Assembling diagram

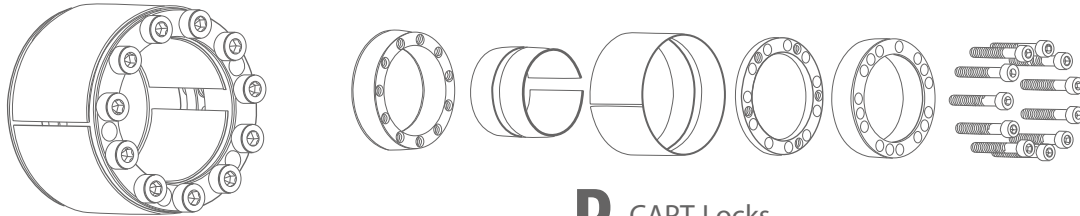

**D** CAPT-Locks

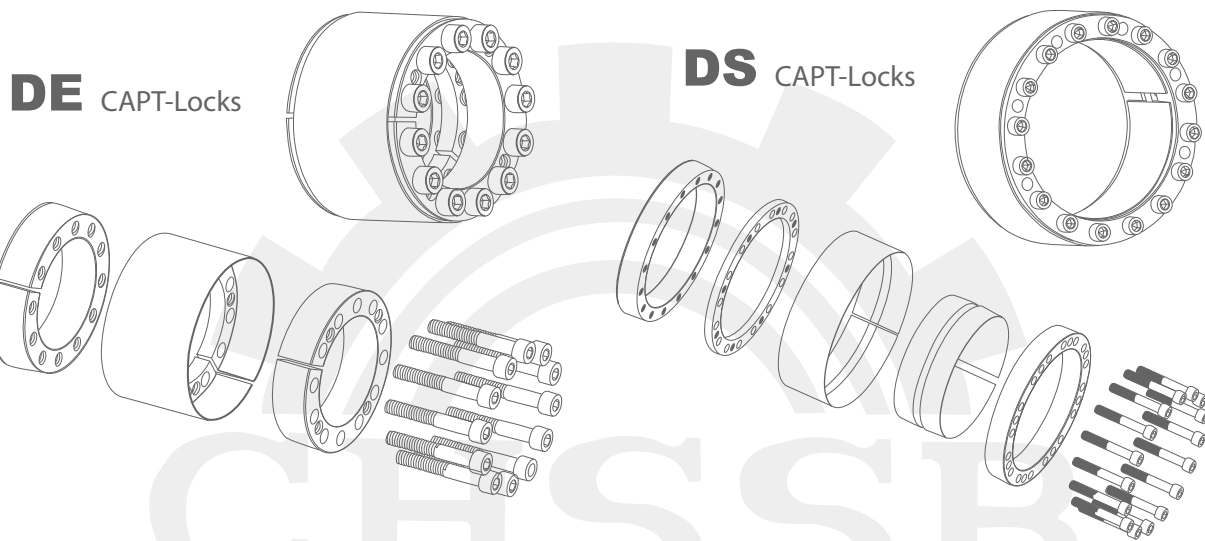

**DE** CAPT-Locks

**DS** CAPT-Locks

### Attention for the usage of CAPT-LOCKS

<p>200°C</p> <p>-30°C</p> <p>1. Temperature for the working surroundings of CAPT-LOCKS is from -30 °C to +200 °C, otherwise, the CAPT-Locks can not work well</p>	<p>N.M</p> <p>3. CAPT-LOCKS can be used and disassembled repeatedly. But after the repeatedly installation and disassembling, the shape of CAPT-LOCKS will be changed little, torque will be reduced slightly.</p>
<p>2. when the CAPT-LOCKS used in open or in the moisture place, it should be protected from rust.</p>	<p>4. If the CAPT-LOCKS is installed with the shaft with keyway, rated torque will be reduced by about 10%.</p>



# CAPT-LOCKS

# DX

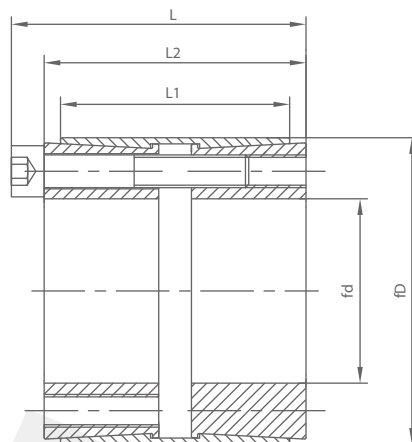
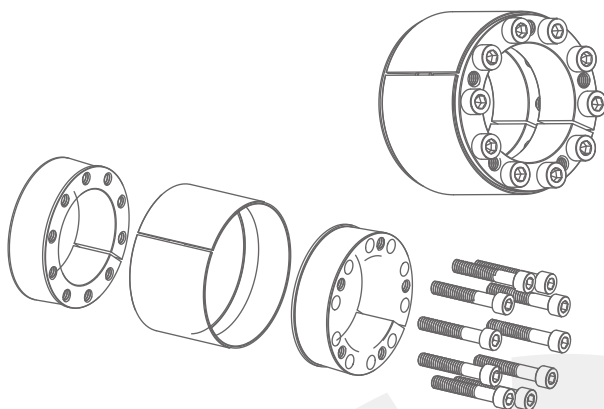

## DX CAPT-LOCKS®

Catalog dxD	Fundamental dimensions			SizesxN	Rated load		Ps Mpa	Ph Mpa	Ma N.m	G Kg
	L1	L2	L		Ft(Kn)	Mt(Kn.m)				
CL20x47DX	39	45	51	M6x8	0.75	58	215	137	17	0.35
CL22x47DX	39	45	51	M6x8	0.82	58	220	140	17	0.3
CL24x50DX	39	45	51	M6x8	0.90	62	220	145	17	0.55
CL25x50DX	39	45	51	M6x8	0.95	76	245	122	17	0.5
CL28x55DX	39	45	51	M6x8	1.07	76	219	111	17	0.6
CL30x55DX	39	45	51	M6x8	1.15	76	204	111	17	0.6
CL35x60DX	39	45	51	M6x8	1.34	76	175	102	17	0.7
CL38x65DX	39	45	51	M6x8	1.45	76	161	94	17	0.7
CL40x65DX	39	45	51	M6x8	1.53	76	153	94	17	0.7
CL42x75DX	56	64	72	M8x8	2.97	141	188	105	41	1.0
CL45x75DX	56	64	72	M8x8	3.15	141	175	105	41	0.9
CL48x80DX	56	64	72	M8x8	4.00	166	164	98	41	1.4
CL50x80DX	56	64	72	M8x8	4.15	166	158	98	41	1.3
CL55x85DX	56	64	72	M8x8	4.55	166	143	93	41	1.5
CL60x90DX	56	64	72	M8x8	6.20	207	164	109	41	1.6
CL65x95DX	56	64	72	M8x8	6.75	207	152	104	41	1.8
CL70x110DX	70	78	88	M10x10	11.55	330	179	114	83	3.0
CL75x115DX	70	78	88	M10x10	12.35	330	167	109	83	3.3
CL80x120DX	70	78	88	M10x12	15.80	396	188	125	83	3.5
CL85x125DX	70	78	88	M10x12	16.80	396	177	120	83	3.7
CL90x130DX	70	78	88	M10x12	17.80	396	167	115	83	3.8
CL95x135DX	70	78	88	M10x12	18.80	396	158	111	83	5.0
CL100x145DX	90	100	112	M12x12	28.80	576	170	117	145	6.0
CL110x155DX	90	100	112	M12x12	31.7	576	155	110	145	6.2
CL120x165DX	90	100	112	M12x14	40.3	673	165	120	145	7.2
CL130x180DX	104	116	130	M14x12	51.4	791	155	112	230	10.0
CL140x190DX	104	116	130	M14x14	64.6	923	168	124	230	10.2
CL150x200DX	104	116	130	M14x16	79.1	1055	179	135	230	10.8
CL160x210DX	104	116	130	M14x16	84.4	1055	168	128	230	11.5
CL170x225DX	134	146	162	M16x14	109.0	1283	149	113	355	17.0
CL180x235DX	134	146	162	M16x16	132	1466	161	124	355	18.5
CL190x250DX	134	146	162	M16x16	139	1466	153	116	355	21.5
CL200x260DX	134	146	162	M16x16	146.5	1466	145	112	355	22.0
CL220x285DX	134	146	162	M16x20	201.5	1833	165	127	355	25.0
CL240x305DX	134	146	162	M16x22	242	2017	166	131	355	27.0
CL260x325DX	134	146	162	M16x22	262	2017	154	123	355	30.0
CL280x355DX	165	177	197	M20x20	400	2862	164	130	690	46.0
CL300x375DX	165	177	197	M20x22	472	3148	169	135	690	50.0
CL320x405DX	165	177	197	M20x22	503.5	3148	158	125	690	60.0
CL340x425DX	165	177	197	M20x24	583.5	3434	162	130	690	65.0
CL360x455DX	190	202	224	M22x22	705	3918	152	120	930	89.0
CL380x475DX	190	202	224	M22x26	880	4631	170	136	930	93.0
CL400x495DX	190	202	224	M22x26	926	4631	162	131	930	98.0

### Key elements for designing and calculation D/DS

1. Determine max torque needed and max axial load

$$Mt_{max} = \frac{30000H}{p \cdot n} \cdot K \text{ (N m)}$$

$$Ft_{max} = Ft \cdot K$$

H--Transmission power KW

n--rotational speed r/min

K--coefficient needed

Sheet for coefficient needed, K

No shock load, transmitting with little inertia	1.5 - 2.5
Slight shock load, transmitting with middle inertia	2.0 - 4.0
Big shock load, transmitting with heavy inertia	3.0 - 5.0

2. Calculate synthetic load and transmitted torque

$$M = \sqrt{Mt^2 - \left(\frac{d}{2} \cdot Ft\right)^2}$$

M--Required transmitted torque N.M

Mt--CAPT lock rated transmitted torque N.m

Ft--Rated axial force N

d--Transmission shaft diameter mm

$Mt \geq M$ , can be used.

$Mt < M$ , need bigger type of CAPT lock or to be installed by two CAPT locks or more together

3. Calculation for the hub diameter

$$Da \geq D \sqrt{\frac{\sigma_b + Ka \cdot Ph}{\sigma_b - Ka \cdot Ph}}$$

Da--outside diameter of hub mm

D--inside diameter of hub mm

Ph--surface pressures on hub Mpa

$\sigma_b$ --tensile strength of material

Ka--It should be 0.6 for single CAPT lock, it will be 0.8 when two CAPT locks or more are installed together

4. Calculation for the inside diameter of cannon

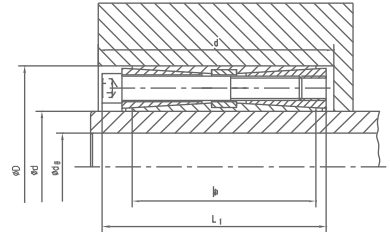

$$dB \leq d \sqrt{\frac{\sigma_b - 2xPs \cdot K3}{\sigma_b}}$$

dB--inside diameter of cannon mm

d--outside diameter of cannon mm

$\sigma_b$ --tensile strength of shaft material Mpa

Ps--pressure on the surface of shaft Mpa

K3--coefficient=0.6

5. Settlement for the surface roughness and dimension tolerance

Cleaning the CAPT-LOCKS, then install it into corresponding position of hub and shaft (Ref Drawing A). Then acc. to the order in Drawing B. Tighten the bolts in turn, the bolts should be tightened step by step in 3 to 4 times up to specified rated torque.

After correct installation, CAPT-LOCKS should be inspected radial and axial runout as per A 0.05mm; B 0.002Rmm.

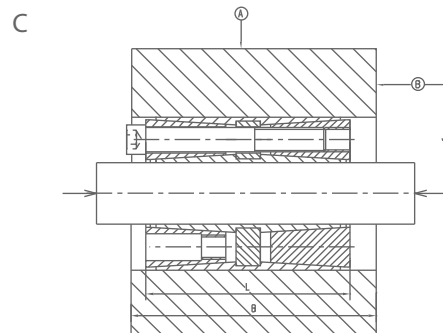
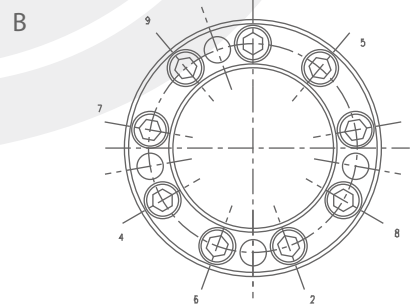
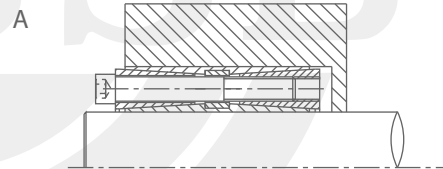

6. Determine the surface roughness and dimension tolerance

Fitting section	surface roughness	Dimension precision
shaft diameter d	1.6/√	h8
bore diameter D	1.6/√	H8

7. Disassembling for CAPT locks

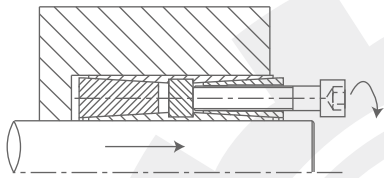

1. Loose and remove all the tightening bolts first, then place the unloading bolts in the corresponding unloading tap hole of the tightening taper ring in A side, tightening and pressing in proper order, separate the tightening taper ring in A side with the inside and outside taper bushes step by step.

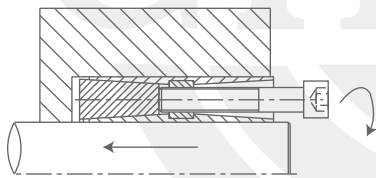

2. After removing the tight taper ring in A side, place the unloading bolts in the corresponding unloading tap hole in the middle ring, tightening and press in proper order, separate the tightening taper ring in B side with the inside and outside taper bushes step by step from the other side.

D type CAPT LOCK can be easily disassembled after the above two steps.

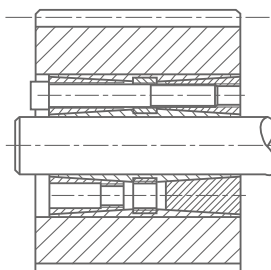

Conventional installation, for the usage of ordinary situation and general power transmission

Used in pairs, Suitable for the usage of greater power transmission

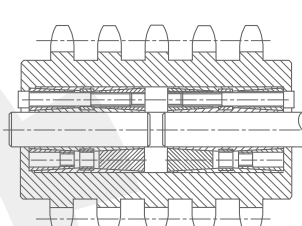

Mounted with shaft sleeves to connect transmission between two shafts. They have the same function with couplings

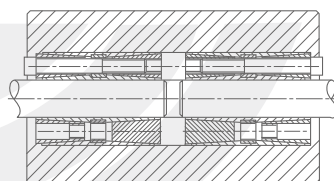

While installed with cams, the position and angle of the cams can be adjusted at will

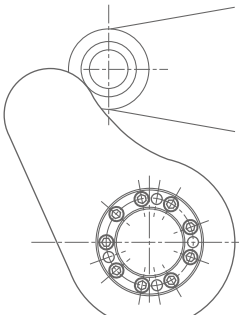

# CAPT-LOCKS

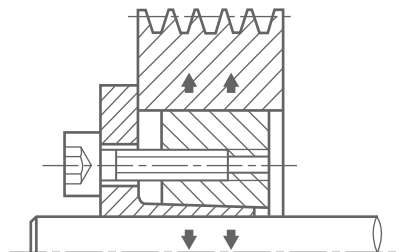

suitable for shaft diameter  
f14~f50(mm)

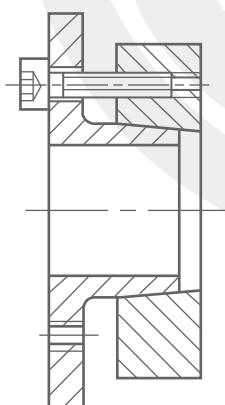
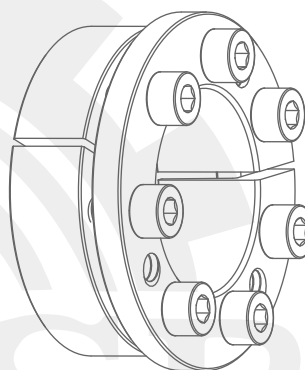
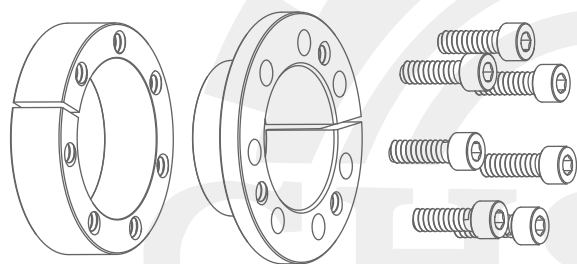

FE CAPT-LOCKS are composed of two inside & outside rings with taper surface and the corresponding tightening bolts. They have the characteristics of simple structure, easy on & easy off and lower costs.

Under the pressure of tightening bolts, the inner and outer rings move oppositely along the inner and outer taper surfaces. The pressure and friction produced make the joint between hub and shaft work.

The installation of FE CAPT-LOCKS is very simple. They can be self-centered installed and their concentricity is very high. The machining process is very simple. The requirement to hub's bore diameter and shaft diameter is not very strict, so the time for machining process time and cost can be saved.

Nomenclature for CAPT-LOCKS FE

**CL 38 X 80 FE**

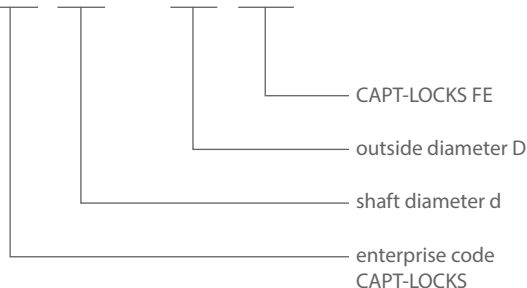

**FE** CAPT-LOCKS

# CAPT-LOCKS

# FE

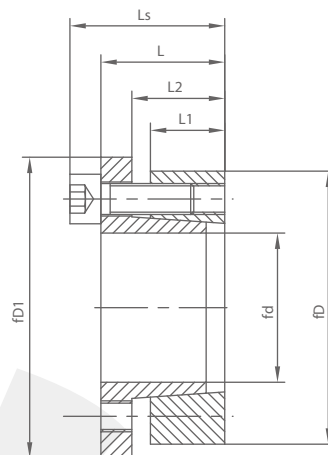

## FE CAPT-LOCKS<sup>®</sup>

Catalog	Fundamental dimensions					SizesxN	Rated load		PS	Ph	Ma	G
	dxD	L1	L2	L	Ls		D1	Ft(Kn)				
CL14x55FE	17	22	30	38	62	M8x3	18	0.127	208	56	25	0.81
CL16x55FE	17	22	30	38	62	M8x3	18	0.142	181	56	25	0.87
CL18x55FE	17	22	30	38	62	M8x3	18	0.157	161	56	25	0.94
CL19x55FE	17	22	30	38	62	M8x3	18	0.165	152	56	25	1.02
CL20x55FE	17	22	30	38	62	M8x3	18	0.172	145	56	25	1.06
CL22x55FE	17	22	30	38	62	M8x3	25.5	0.285	186	75	35	1.70
CL24x55FE	17	22	30	38	62	M8x3	25.5	0.307	170	75	35	1.79
CL25x55FE	17	22	30	38	62	M8x3	25.5	0.315	163	75	35	1.89
CL28x55FE	17	22	30	38	62	M8x3	31.5	0.395	175	91	41	1.98
CL30x55FE	17	22	30	38	62	M8x3	31.5	0.425	163	91	41	2.15
CL24x65FE	17	22	30	38	72	M8x5	37.4	0.44	244	91	41	0.94
CL25x65FE	17	22	30	38	72	M8x5	37.4	0.46	234	91	41	1.02
CL28x65FE	17	22	30	38	72	M8x5	43.6	0.6	243	105	35	1.06
CL30x65FE	17	22	30	38	72	M8x5	43.6	0.64	227	105	35	1.70
CL32x65FE	17	22	30	38	72	M8x5	43.6	0.69	213	105	35	1.79
CL35x65FE	17	22	30	38	72	M8x5	52.5	0.81	234	126	41	1.89
CL38x65FE	17	22	30	38	72	M8x5	52.5	0.95	216	126	41	1.98
CL40x65FE	17	22	30	38	72	M8x5	52.5	0.99	205	126	41	2.15
CL30x80FE	20	25	33	41	87	M8x7	56.5	0.78	232	87	30	1.70
CL32x80FE	20	25	33	41	87	M8x7	56.5	0.83	218	87	30	1.79
CL35x80FE	20	25	33	41	87	M8x7	61	1.06	232	102	35	1.89
CL38x80FE	20	25	33	41	87	M8x7	61	1.15	214	102	35	1.98
CL40x80FE	20	25	33	41	87	M8x7	61	1.22	203	102	41	2.15
CL42x80FE	20	25	33	41	87	M8x7	73.5	1.36	233	123	41	2.24
CL45x80FE	20	25	33	41	87	M8x7	73.5	1.55	217	123	41	3.07
CL48x80FE	20	25	33	41	87	M8x7	73.5	1.66	203	123	41	3.35
CL50x80FE	20	25	33	41	87	M8x7	73.5	1.73	195	123	41	3.59

# CAPT-LOCKS

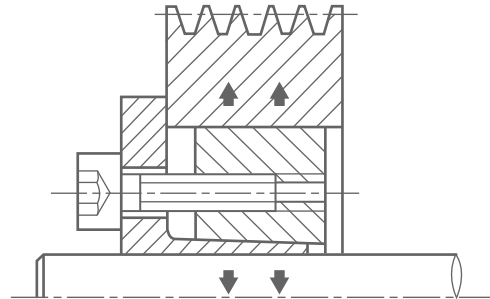

45suit for shaft diameter  
metric:f18~f400(mm)

FA CAPT-LOCKS are the extension series of FE type. The scope of bore diameter is from 18mm to 400mm and the biggest outside diameter D can reach 495mm. Their suitability to installation is very high. They are widely used in general mechanical joints.

Under the pressure of tightening bolts, the inner and outer rings moving along the taper surface oppositely caused radial pressure and frictional force, which join the hubs and shafts together.

FA CAPT -LOCKS are divided into two types:FA1 and FA2. The only difference is in the flange diameter of inner ring. As for FA1 type, the flange diameter of inner ring is 6mm bigger than outer ring. While as for FA2 type, the flange diameter of inner ring is the same as outside ring.

The installation of FA CAPT-LOCKS is very simple. They can be self-centered installed and their concentricity is very high. The processing is very simple. The requirement to hub's bore diameter and shaft diameter is not very strict, so that the time and cost for machining process can be saved.

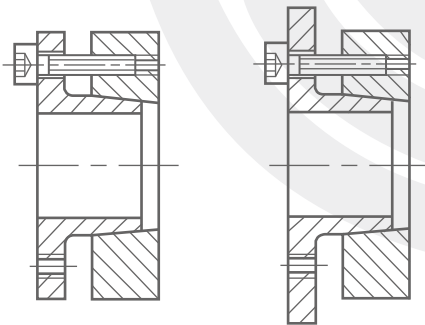

FA1

FA2

Nomenclature for CAPT-LOCKS type D

CL 50 X 80 FA

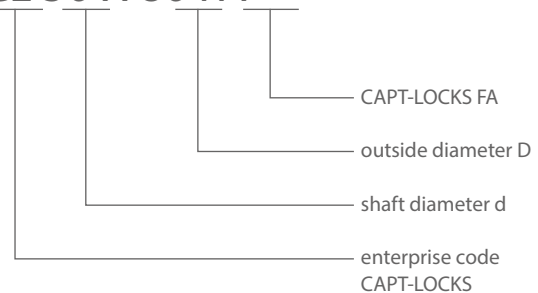

## FA CAPT-LOCKS

# CAPT-LOCKS

# FA1

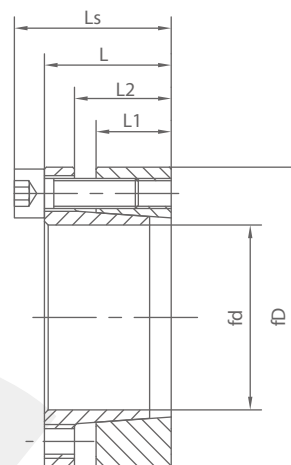
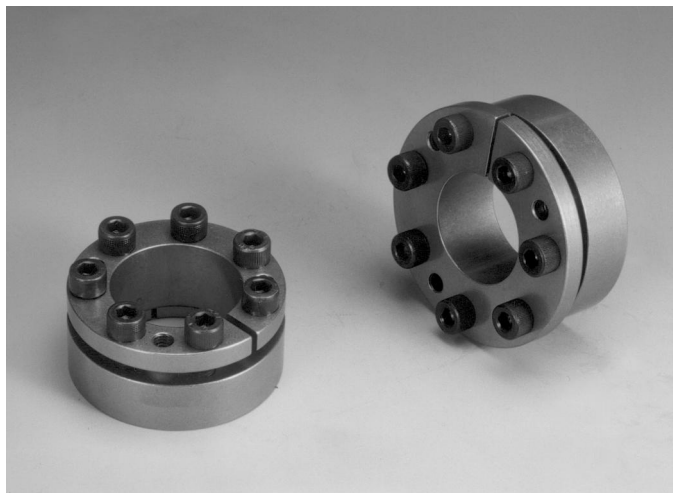

## FA1 CAPT-LOCKS<sup>®</sup>

Table:1

Catalog	Fundamental dimensions				SizesxN	Rated load		Ps Mpa	Ph Mpa	Ma N.m	G Kg
	dxD	L1	L2	L		Ls	Ft(Kn)				
CL18x47FA1	17	22	28	34	M6x5	34	0.31	314	125	14	0.26
CL19x47FA1	17	22	28	34	M6x5	35	0.33	297	125	14	0.27
CL20x47FA1	17	22	28	34	M6x5	38	0.38	295	125	14	0.27
CL22x47FA1	17	22	28	34	M6x5	38	0.41	270	125	14	0.28
CL24x50FA1	17	22	28	34	M6x5	38	0.45	245	120	14	0.29
CL25x50FA1	17	22	28	34	M6x6	45.6	0.57	285	140	14	0.29
CL28x55FA1	17	22	28	34	M6x6	45.6	0.63	255	130	14	0.35
CL30x55FA1	17	22	28	34	M6x6	45.6	0.66	235	130	14	0.36
CL32x60FA1	17	22	28	34	M6x8	60.6	0.97	295	155	14	0.44
CL35x60FA1	17	22	28	34	M6x8	60.6	1.06	270	155	14	0.47
CL38x65FA1	17	22	28	34	M6x8	60.6	1.15	250	145	14	0.48
CL40x65FA1	17	22	28	34	M6x8	60.6	1.21	235	145	14	0.55
CL42x75FA1	20	25	33	41	M8x7	98	2.05	295	170	35	0.76
CL45x75FA1	20	25	33	41	M8x7	98	2.2	290	170	35	0.78
CL48x80FA1	20	25	33	41	M8x7	98	2.35	270	160	35	0.81
CL50x80FA1	20	25	33	41	M8x7	98	2.45	260	160	35	0.87
CL55x85FA1	20	25	33	41	M8x8	112	3.08	270	175	35	0.94
CL60x90FA1	20	25	33	41	M8x8	112	3.36	245	165	35	1.00
CL63x95FA1	20	25	33	41	M8x9	126	3.87	260	175	35	1.06
CL65x95FA1	20	25	33	41	M8x9	126	4.09	250	175	35	1.70
CL70x110FA1	24	30	40	50	M10x8	179	6.3	280	180	70	1.79
CL75x115FA1	24	30	40	50	M10x8	179	6.7	260	170	70	1.89
CL80x120FA1	24	30	40	50	M10x8	179	7.15	250	170	70	1.98
CL85x125FA1	24	30	40	50	M10x9	200	8.5	260	180	70	2.15
CL90x130FA1	24	30	40	50	M10x9	200	9.1	250	170	70	2.24
CL95x135FA1	24	30	40	50	M10x10	224	10.6	260	180	70	3.07
CL100x145FA1	26	32	44	56	M12x8	268	13.4	270	190	125	3.35
CL110x155FA1	26	32	44	56	M12x8	268	14.6	240	180	125	3.59
CL120x165FA1	26	32	44	56	M12x9	298	17.9	250	180	125	5.04
CL130x180FA1	34	40	54	68	M12x12	400	26	240	170	125	5.33

Note: All the items listed above are for the standard parts in stock

# CAPT-LOCKS

# FA1

## FA1 CAPT-LOCKS®

Table:1

Catalog dxD	Fundamental dimensions				SizesxN	Rated load		Ps Mpa	Ph Mpa	Ma N.m	G Kg
	L1	L2	L	Ls		Ft(Kn)	Mt(Kn.m)				
CL140x190FA1	34	40	54	68	M14x9	384	27	210	150	190	5.81
CL150x200FA1	34	40	54	68	M14x10	440	33	230	170	190	6.67
CL160x210FA1	34	40	54	68	M14x11	470	38	230	170	190	7.61
CL170x225FA1	44	50	64	78	M14x12	530	45	180	130	190	8.05
CL180x235FA1	44	50	64	78	M14x12	530	47	170	130	190	8.9
CL190x250FA1	44	50	64	78	M14x15	590	49	210	150	190	9.58
CL200x260FA1	44	50	64	78	M14x15	590	52	190	150	190	10.7
CL220x285FA1	50	56	72	88	M16x12	587	64.5	145	110	355	14.4
CL240x305FA1	50	56	72	88	M16x15	734	88	165	130	355	15.5
CL260x325FA1	50	56	72	88	M16x18	880	114	180	145	355	16.7
CL280x355FA1	60	66	84	102	M18x16	948	132	150	120	485	24.0
CL300x375FA1	60	66	84	102	M18x18	1059	159	160	125	485	25.5
CL320x405FA1	74	81	101	121	M20x18	1374	220	150	120	690	38.0
CL340x425FA1	74	81	101	121	M20x21	1603	272	175	135	690	40.0
CL360x455FA1	86	94	116	138	M22x18	1710	308	140	110	930	48.0
CL380x475FA1	86	94	116	138	M22x21	1995	379	155	125	930	57.0
CL400x495FA1	86	94	116	138	M22x21	1995	399	150	120	930	63.0

Note: All the items listed in the above table will be produced against orders

## FA1 CAPT-LOCKS Assembling diagram:

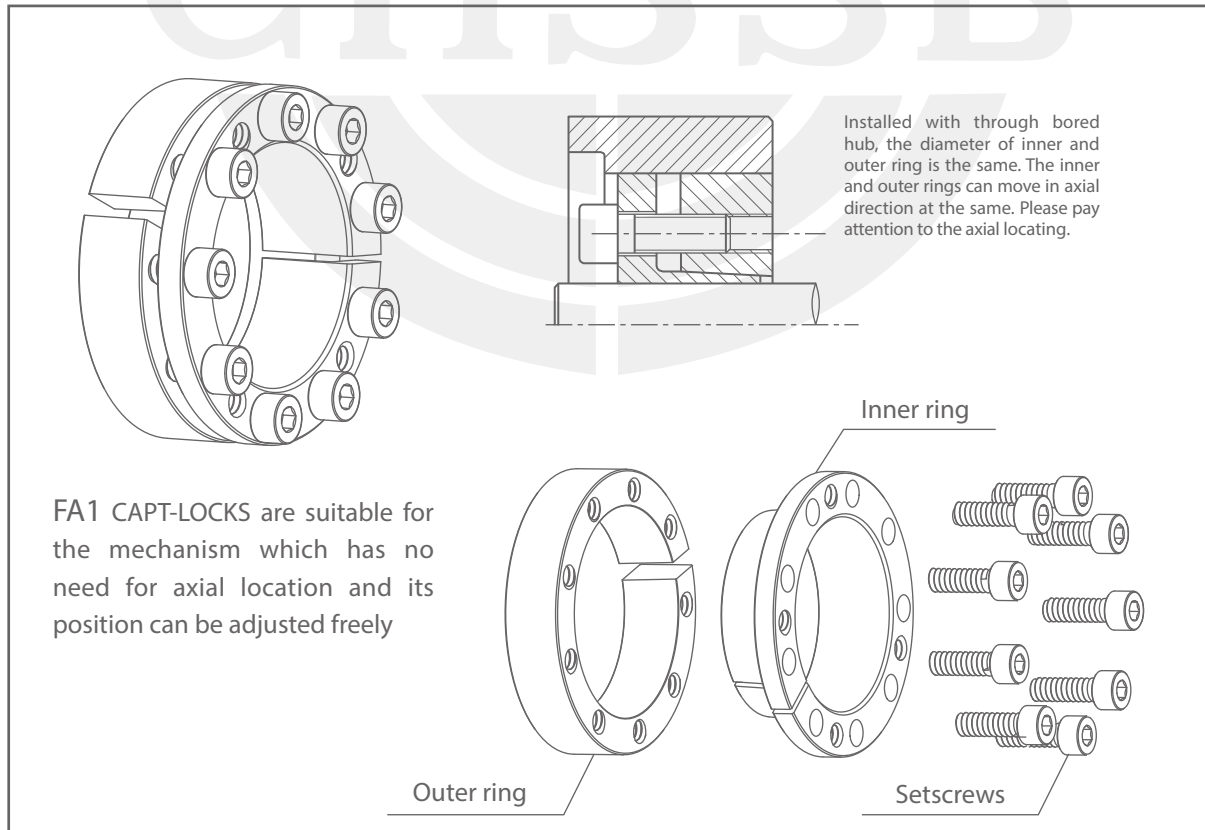



# CAPT-LOCKS

# FA2

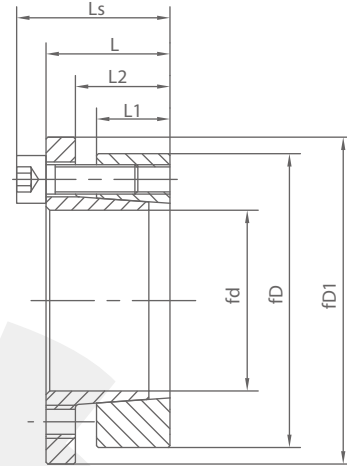

## FA2 CAPT-LOCKS<sup>®</sup>

Table:1

Catalog dxD	Fundamental dimensions					SizesxN	Rated load		Ps Mpa	Ph Mpa	Ma N.m	G Kg
	L1	L2	L	Ls	D1		Ft(Kn)	Mt(Kn.m)				
CL18x47FA2	17	22	28	34	56	M6x5	28	0.25	241	95	17	0.26
CL19x47FA2	17	22	28	34	56	M6x5	28	0.26	229	95	17	0.27
CL20x47FA2	17	22	28	34	56	M6x5	28	0.28	220	95	17	0.27
CL22x47FA2	17	22	28	34	56	M6x5	28	0.30	200	95	17	0.28
CL24x50FA2	17	22	28	34	59	M6x5	28	0.33	180	90	17	0.29
CL25x50FA2	17	22	28	34	59	M6x6	34	0.42	210	105	17	0.29
CL28x55FA2	17	22	28	34	64	M6x6	34	0.47	190	95	17	0.35
CL30x55FA2	17	22	28	34	64	M6x6	34	0.50	175	95	17	0.40
CL32x60FA2	17	22	28	34	69	M6x8	45	0.72	220	115	17	0.44
CL35x60FA2	17	22	28	34	69	M6x8	45	0.79	200	115	17	0.48
CL38x65FA2	17	22	28	34	74	M6x8	45	0.85	185	105	17	0.48
CL40x65FA2	17	22	28	34	74	M6x8	45	0.90	175	105	17	0.55
CL42x75FA2	20	25	33	41	84	M8x7	73	1.49	225	125	41	0.76
CL45x75FA2	20	25	33	41	84	M8x7	73	1.60	215	125	41	0.80
CL48x80FA2	20	25	33	41	89	M8x7	73	1.71	200	120	41	0.81
CL50x80FA2	20	25	33	41	89	M8x7	73	1.79	195	120	41	0.87
CL55x95FA2	20	25	33	41	94	M8x8	83	2.10	200	130	41	0.96
CL60x90FA2	20	25	33	41	99	M8x8	83	2.32	185	125	41	1.00
CL63x95FA2	20	25	33	41	104	M8x9	94	2.51	188	130	41	1.06
CL65x95FA2	20	25	33	41	104	M8x9	94	2.98	190	130	41	1.70
CL70x110FA2	24	30	40	50	119	M10x8	133	4.63	210	135	83	1.79
CL75x115FA2	24	30	40	50	124	M10x8	133	5.00	195	125	83	1.95
CL80x120FA2	24	30	40	50	129	M10x8	133	5.30	185	125	83	1.98
CL85x125FA2	24	30	40	50	134	M10x9	148	6.30	195	135	83	2.20
CL90x130FA2	24	30	40	50	139	M10x9	148	6.75	185	130	83	2.28
CL95x135FA2	24	30	40	50	144	M10x10	166	7.90	195	135	83	3.20
CL100x145FA2	26	32	44	56	154	M12x8	194	9.70	200	140	145	3.40
CL110x155FA2	26	32	44	56	164	M12x8	194	10.6	180	130	145	3.65
CL120x165FA2	26	32	44	56	174	M12x9	216	13.0	185	135	145	5.25
CL130x180FA2	34	40	54	68	189	M12x12	290	18.9	175	125	145	5.63

Note: All the items listed above are for the standard parts in stock

# CAPT-LOCKS

# FA2

## FA2 CAPT-LOCKS<sup>®</sup>

Table:2

Catalog dxD	Fundamental dimensions					SizesxN	Rated load		Ps Mpa	Ph Mpa	Ma N.m	G Kg
	L1	L2	L	Ls	D1		Ft(Kn)	Mt(Kn.m)				
CL140x190FA2	34	40	54	68	199	M14x9	290	20.5	165	120	230	5.95
CL150x200FA2	34	40	54	68	209	M14x10	333	24.5	175	130	230	6.89
CL160x210FA2	34	40	54	68	219	M14x11	362	28.9	180	135	230	7.85
CL170x225FA2	44	50	64	78	234	M14x12	400	33.2	140	105	230	8.32
CL180x235FA2	44	50	64	78	244	M14x12	400	35.6	135	105	230	9.12
CL190x250FA2	44	50	64	78	259	M14x15	500	46.5	160	120	230	9.58
CL200x260FA2	44	50	64	78	269	M14x15	500	48.3	150	115	230	11.7
CL220x285FA2	50	56	72	88	294	M16x12	578	58.0	145	110	355	15.9
CL240x305FA2	50	56	72	88	314	M16x15	725	79.0	165	130	355	16.5
CL260x325FA2	50	56	72	88	334	M16x18	830	102	180	145	355	17.7
CL280x355FA2	60	66	84	102	364	M18x16	925	118	150	120	485	24.0
CL300x375FA2	60	66	84	102	384	M18x18	1050	142	160	125	485	25.5
CL320x405FA2	74	81	101	121	414	M20x18	1365	198	150	120	690	38.0
CL340x425FA2	74	81	101	121	434	M20x21	1590	230	175	135	690	40.0
CL360x455FA2	86	94	116	138	464	M22x18	1675	256	140	110	930	48.0
CL380x475FA2	86	94	116	138	484	M22x21	1980	310	155	125	930	57.0
CL400x495FA2	86	94	116	138	504	M22x21	1980	352	150	120	930	63.0

Note: All the items listed in the above table will be produced against orders

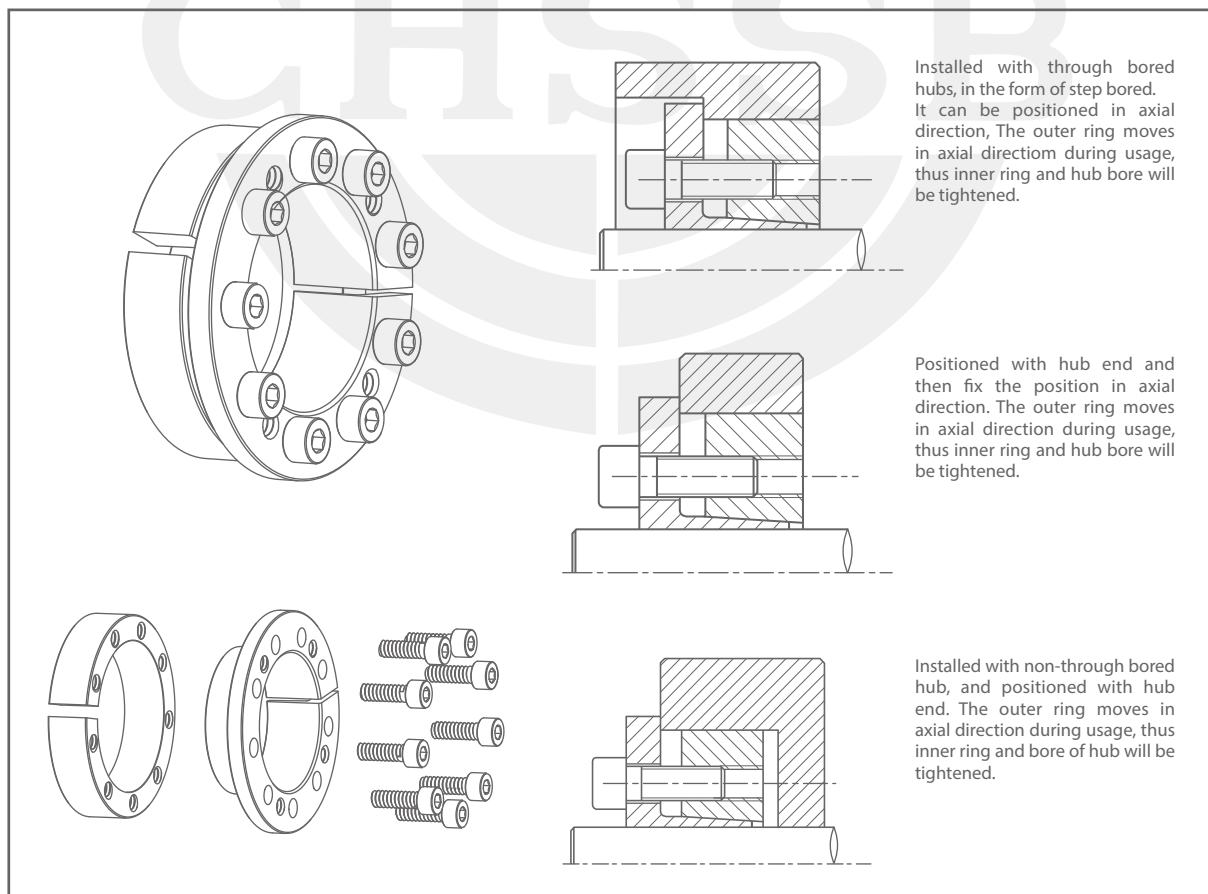

# CAPT-LOCKS

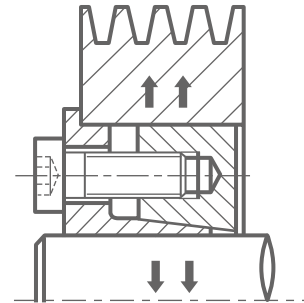

suitable for shaft diameter  
metric:f19~f220(mm)

FB CAPT-LOCKS are composed of two inner & outer rings with taper surface and the corresponding tightening bolts. They have the characteristics of simple structure,easy on & easy off and lower costs.

Under the pressure of tightening bolts, the inner and outer rings moving along the taper surface oppositely caused radial pressure and frictional force, which join the hubs and shafts together.

FB CAPT-LOCKS are divided into two types:FB1 and FB2. The only difference is in the flange diameter of inner ring. As for FB1 type, the flange diameter of inner ring is 6mm bigger than outer ring. While as for FB2 type, the flange diameter of inner ring is the same as outer ring.

The installation of FB CAPT-LOCKS is very simple. They can be self-centered installed and their concentricity is very high. The machining process is very simple. The requirement to hub's bore diameter and shaft diameter is not very strict, so that the time for machining process and cost can be saved.

FB CAPT-LOCKS are the heavier series of FA type. The scope of bore diameter is from 19mm to 220mm and the biggest outside diameter D can reach 285mm, Their suitability for installation is very high. They can be widely used in general mechanical joints and can transmit bigger torque.

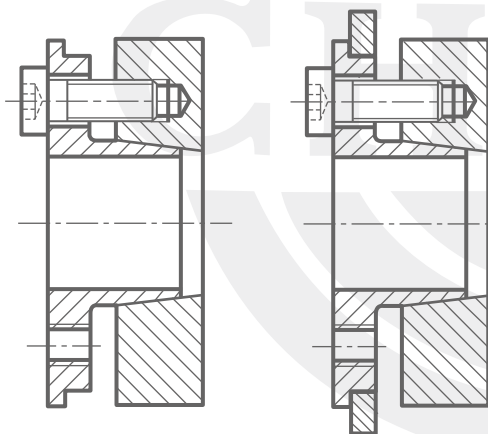

FB1

FB2

Nomenclature for CAPT-LOCKS FB:

CL 50 X 80 FB1

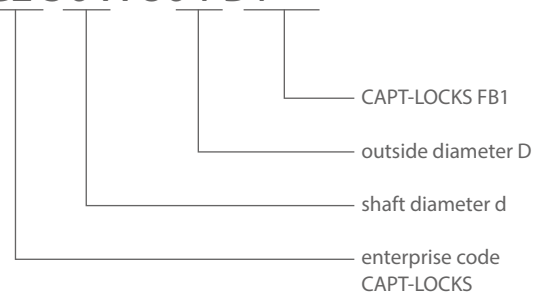

## FB CAPT-LOCKS

# CAPT-LOCKS

# FB1

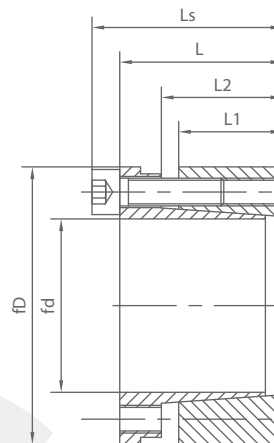

## FB1 CAPT-LOCKS®

Catalog	Fundamental dimensions				SizesxN	Rated load		Ps Mpa	Ph Mpa	Ma N.m	G Kg
	L1	L2	L	Ls		Ft(Kn)	Mt(Kn.m)				
CL19x47FB1	26	30	39	45	M6x6	54	0.54	260	105	17	0.35
CL20x47FB1	26	30	39	45	M6x6	54	0.55	250	105	17	0.36
CL22x47FB1	26	30	39	45	M6x6	54	0.6	230	105	17	0.44
CL24x50FB1	26	30	39	45	M6x6	54	0.65	210	100	17	0.47
CL25x50FB1	26	30	39	45	M6x6	54	0.68	200	100	17	0.48
CL28x55FB1	26	30	39	45	M6x6	54	0.78	180	95	17	0.55
CL30x55FB1	26	30	39	45	M6x6	54	0.82	170	95	17	0.76
CL32x60FB1	26	30	39	45	M6x9	82	1.31	246	131	17	0.79
CL35x60FB1	26	30	39	45	M6x9	82	1.44	225	131	17	0.81
CL38x65FB1	26	30	39	45	M6x9	82	1.56	207	121	17	0.87
CL40x65FB1	26	30	39	45	M6x9	82	1.64	197	121	17	0.94
CL42x75FB1	30	35	47	55	M8x6	99	2.08	215	120	41	1.02
CL45x75FB1	30	35	47	55	M8x6	99	2.23	200	120	41	1.06
CL48x80FB1	30	35	47	55	M8x6	99	2.33	215	115	41	1.7
CL50x80FB1	30	35	47	55	M8x6	99	2.43	201	115	41	1.79
CL55x85FB1	30	35	47	55	M8x9	152	4.18	244	160	41	1.89
CL60x90FB1	30	35	47	55	M8x9	152	4.56	225	152	41	1.98
CL65x95FB1	30	35	47	55	M8x9	152	4.94	210	145	41	2.15
CL70x110FB1	40	46	67	77	M10x7	186	6.5	214	136	83	2.24
CL75x115FB1	40	46	67	77	M10x7	186	7	200	130	83	3.07
CL80x120FB1	40	46	67	77	M10x7	186	7.4	187	125	83	3.35
CL85x125FB1	40	46	67	77	M10x8	213	9	200	140	83	3.59
CL90x130FB1	40	46	67	77	M10x8	213	9.6	188	134	83	5.04
CL95x135FB1	40	46	67	77	M10x10	267	12.6	197	139	83	5.38
CL100x145FB1	46	52	77	89	M12x7	270	13.3	174	117	145	5.81
CL110x155FB1	46	52	77	89	M12x7	270	14.7	158	109	145	6.67
CL120x165FB1	46	52	77	89	M12x8	309	18.4	182	130	145	7.61
CL130x180FB1	46	52	77	89	M12x10	388	25.1	193	134	145	8.05
CL140x190FB1	51	59	88	102	M14x11	485	36.2	203	152	230	8.9
CL150x200FB1	51	59	88	102	M14x12	551	41.3	216	162	230	9.58
CL160x210FB1	51	59	88	102	M14x13	651	50.5	213	165	230	10.7
CL170x225FB1	51	59	88	102	M14x14	643	54.6	223	168	230	11.7
CL180x235FB1	51	59	88	102	M14x14	643	57.8	210	161	230	13.5
CL190x250FB1	51	59	88	102	M14x15	689	65.4	214	162	230	15.4
CL200x260FB1	51	59	88	102	M14x15	689	68.8	203	156	230	17.9
CL220x285FB1	64	72	106	122	M16x12	948	88.1	210	165	355	20.3

# CAPT-LOCKS

# FB2

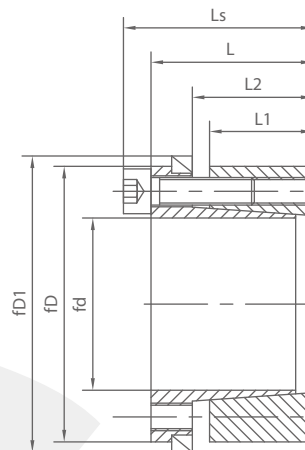

## FB2 CAPT-LOCKS®

Catalog	Fundamental dimensions					SizesxN	Rated load		Ps	Ph	Ma	G
	dxD	L1	L2	L	Ls		D	Ft(Kn)				
CL19x47FB2	26	30	39	45	53	M6x6	33	0.32	191	77	17	0.37
CL20x47FB2	26	30	39	45	53	M6x6	33	0.34	181	77	17	0.39
CL22x47FB2	26	30	39	45	53	M6x6	33	0.37	165	77	17	0.46
CL24x50FB2	26	30	39	45	53	M6x6	33	0.4	151	72	17	0.50
CL25x50FB2	26	30	39	45	53	M6x6	33	0.42	145	72	17	0.51
CL28x55FB2	26	30	39	45	61	M6x6	33	0.47	129	66	17	0.59
CL30x55FB2	26	30	39	45	61	M6x6	33	0.51	121	66	17	0.79
CL32x60FB2	26	30	39	45	66	M6x9	50	0.72	161	87	17	0.83
CL35x60FB2	26	30	39	45	66	M6x9	50	0.79	148	87	17	0.85
CL38x65FB2	26	30	39	45	71	M6x9	50	0.85	137	76	17	0.95
CL40x65FB2	26	30	39	45	71	M6x9	50	0.9	131	76	17	0.97
CL42x75FB2	30	35	47	55	81	M8x6	60	1.28	135	78	41	1.12
CL45x75FB2	30	35	47	55	81	M8x6	60	1.37	126	78	41	1.16
CL48x80FB2	30	35	47	55	86	M8x6	60	1.47	141	81	41	1.81
CL50x80FB2	30	35	47	55	86	M8x6	60	1.52	128	81	41	1.83
CL55x85FB2	30	35	47	55	91	M8x9	90	2.24	148	98	41	1.89
CL60x90FB2	30	35	47	55	96	M8x9	90	2.44	136	94	41	1.98
CL65x95FB2	30	35	47	55	101	M8x9	90	2.98	126	90	41	2.25
CL70x110FB2	40	46	67	77	116	M10x7	115	3.87	126	84	83	2.34
CL75x115FB2	40	46	67	77	121	M10x7	115	4.33	118	80	83	3.27
CL80x120FB2	40	46	67	77	126	M10x7	115	4.62	110	77	83	3.35
CL85x125FB2	40	46	67	77	131	M10x8	130	5.58	125	82	83	3.69
CL90x130FB2	40	46	67	77	136	M10x8	130	6.00	118	78	83	5.34
CL95x135FB2	40	46	67	77	141	M10x10	160	7.62	111	85	83	5.48
CL100x145FB2	46	52	77	89	151	M12x7	170	8.32	114	82	145	5.86
CL110x155FB2	46	52	77	89	161	M12x7	170	9.23	103	77	145	6.77
CL120x165FB2	46	52	77	89	171	M12x8	185	11.37	114	85	145	7.71
CL130x180FB2	46	52	77	89	186	M12x10	220	15.68	127	90	145	8.25
CL140x190FB2	51	59	88	102	196	M14x11	325	22.80	130	96	230	8.29
CL150x200FB2	51	59	88	102	206	M14x12	380	29.32	146	109	230	9.78
CL160x210FB2	51	59	88	102	216	M14x13	392	31.27	146	110	230	10.37
CL170x225FB2	51	59	88	102	231	M14x14	450	38.77	150	113	230	12.55
CL180x235FB2	51	59	88	102	241	M14x14	450	41.05	141	108	230	13.45
CL190x250FB2	51	59	88	102	256	M14x15	480	46.42	144	109	230	15.44
CL200x260FB2	51	59	88	102	266	M14x15	480	48.86	136	105	230	17.59
CL220x285FB2	64	72	106	122	291	M16x12	582	58.20	150	110	355	20.85

# CAPT-LOCKS

# FC

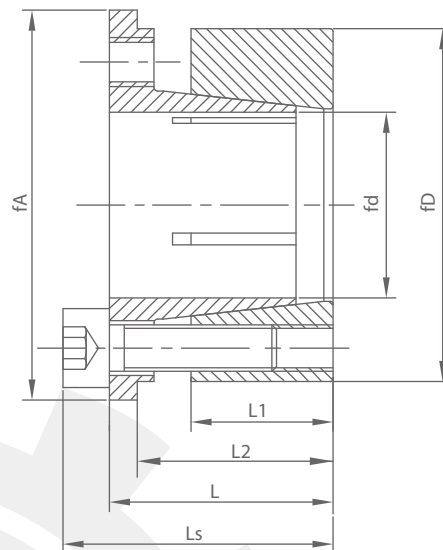

## FC CAPT-LOCKS<sup>®</sup>

Catalog dxD	Fundamental dimensions					SizesxN	Rated load		Ps Mpa	Ph Mpa	Ma N.m	G Kg
	A	L1	L2	L	Ls		Ft(Kn)	Mt(Kn.m)				
CL5x16FC	18.5	8.0	11.2	13.0	16.0	M3x4	4.89	0.010	191	110	2	0.02
CL6x19FC	21.5	9.0	12.3	14.3	18.3	M4x4	9.16	0.015	181	120	5	0.03
CL6.35x20FC	22.5	9.0	12.3	14.3	18.3	M4x4	9.16	0.019	165	119	5	0.03
CL8x21FC	23.5	9.3	12.6	14.6	18.6	M4x4	9.16	0.028	151	112	5	0.04
CL10x23FC	25.5	9.5	12.8	14.8	18.8	M4x4	9.16	0.041	145	108	5	0.04
CL11x24FC	26.5	9.5	13.8	15.8	19.8	M4x4	9.16	0.046	129	104	5	0.04
CL12x26FC	28.5	10.5	15.5	18.0	22.0	M4x6	13.75	0.068	141	106	5	0.06
CL14x28FC	30.5	10.5	15.5	18.0	22.0	M4x6	13.75	0.096	161	121	5	0.06
CL15x29FC	31.5	11.5	16.5	19.0	23.0	M4x6	13.75	0.098	148	106	5	0.07
CL16x30FC	33.0	12.0	17.1	19.6	23.6	M4x6	13.75	0.101	137	99	5	0.07
CL17x31FC	33.5	12.5	17.6	20.1	24.1	M4x8	18.33	0.144	131	118	5	0.08
CL18x32FC	34.5	12.5	17.6	20.1	24.1	M4x8	18.33	0.153	135	118	5	0.08
CL19x33FC	35.5	12.5	17.6	20.1	24.1	M4x8	18.33	0.164	126	102	5	0.08
CL20x38FC	42.0	15.3	21.1	24.1	29.1	M5x8	29.33	0.251	141	110	10	0.13
CL22x40FC	44.0	15.3	21.1	24.1	29.1	M5x8	29.33	0.308	148	110	10	0.14
CL24x42FC	46.0	16.3	22.1	25.1	30.1	M5x8	29.33	0.332	148	111	10	0.16
CL25x43FC	47.0	17.3	23.1	26.1	31.1	M5x8	29.33	0.347	136	102	10	0.17
CL28x46FC	50.0	17.3	23.1	26.6	31.6	M5x10	36.66	0.490	146	119	10	0.19
CL30x48FC	52.0	17.3	23.1	26.6	31.6	M5x10	36.66	0.525	126	110	10	0.19
CL32x50FC	54.0	18.3	24.1	27.6	32.6	M5x10	36.66	0.563	118	104	10	0.21
CL35x57FC	62.0	19.5	26.0	30.0	36.0	M6x8	41.55	0.702	120	103	17	0.32
CL38x60FC	65.0	20.0	26.5	30.5	36.5	M6x10	51.93	0.955	125	101	17	0.35
CL40x62FC	67.0	20.5	27.0	31.0	37.0	M6x10	51.93	1.019	118	101	17	0.36
CL42x64FC	69.0	20.5	27.0	31.0	37.0	M6x10	51.93	1.061	120	111	17	0.38
CL45x67FC	72.0	21.0	27.5	31.5	37.5	M6x10	51.93	1.138	118	110	17	0.40
CL48x70FC	75.0	21.0	27.5	32.0	38.0	M6x12	62.32	1.446	129	103	17	0.44
CL50x72FC	77.0	21.5	27.5	32.5	38.5	M6x14	72.70	1.768	143	114	17	0.46
CL55x77FC	83.0	21.5	27.5	32.5	38.5	M6x14	72.70	1.939	133	121	17	0.50
CL60x82FC	87.0	22.0	28.5	33.5	39.5	M6x15	77.90	2.287	131	121	17	0.52
CL65x87FC	92.0	22.0	28.5	33.5	39.5	M6x15	77.90	2.432	146	124	17	0.55
CL70x97FC	103	24.0	31.1	36.1	44.1	M8x14	131.5	4.415	169	141	41	0.87
CL75x102FC	108	24.0	31.1	36.1	44.1	M8x15	140.9	5.154	172	150	41	0.87
CL80x107FC	113	25.0	32.1	37.1	45.1	M8x15	140.9	5.536	158	141	41	0.93
CL85x112FC	118	25.0	32.1	37.1	45.1	M8x15	140.9	5.886	151	144	41	0.97

# CAPT-LOCKS

# FD

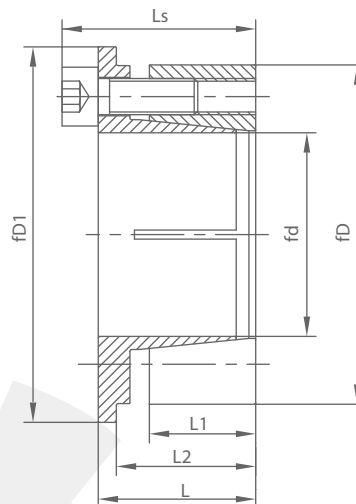
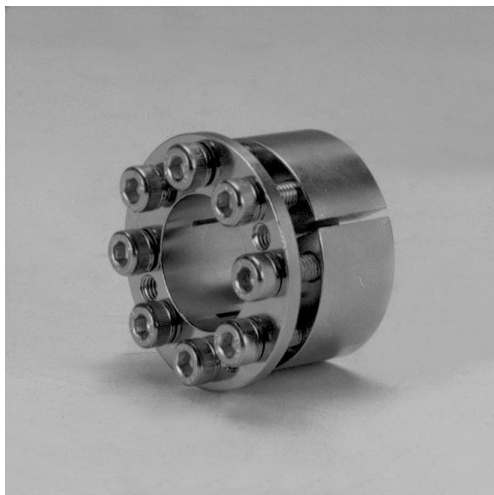

## FD CAPT-LOCKS<sup>®</sup>

Catalog	Fundamental dimensions					Screw bolt	Rated load		Ps	Ph	Ma	G
	dxD	D1	L1	L2	L		Ls	SizesxN				
CL19x47FD	53	19	24.8	27.3	33.3	M6x6	0.265	28.1	287	93	17	0.28
CL20x47FD	53	19	24.8	27.3	33.3	M6x6	0.274	28.1	272	93	17	0.27
CL22x47FD	53	19	24.8	27.3	33.3	M6x6	0.304	28.1	248	93	17	0.26
CL24x50FD	57	19	25.3	27.8	33.8	M6x7	0.392	32.8	274	102	17	0.29
CL25x50FD	57	19	25.3	27.8	33.8	M6x7	0.412	32.8	282	102	17	0.28
CL28x55FD	62	19	25.3	28.6	34.6	M6x8	0.519	37.5	269	106	17	0.35
CL30x55FD	62	19	25.3	28.6	34.6	M6x8	0.559	37.5	251	106	17	0.34
CL32x60FD	67	20.5	27.3	30.9	36.9	M6x10	0.745	46.9	267	113	17	0.44
CL35x60FD	67	20.5	27.3	30.9	36.9	M6x10	0.823	46.9	244	113	17	0.41
CL38x65FD	73	20.5	27.5	31.1	37.1	M6x10	0.892	46.9	228	104	17	0.48
CL40x65FD	73	20.5	27.5	31.1	37.1	M6x10	0.931	46.9	217	104	17	0.45
CL42x75FD	83	23.5	30.8	34.8	42.8	M8x9	1.64	78.1	285	130	41	0.76
CL45x75FD	83	23.5	30.8	34.8	42.8	M8x9	1.75	78.1	266	130	41	0.71
CL48x80FD	88	23.5	31.0	35.0	43.0	M8x10	2.06	86.8	280	136	41	0.81
CL50x80FD	88	23.5	31.0	35.0	43.0	M8x10	2.16	86.8	270	136	41	0.77
CL55x85FD	94	23.5	30.8	34.8	42.8	M8x10	2.35	86.8	242	128	41	0.84
CL60x90FD	99	23.5	30.8	34.8	42.8	M8x10	2.55	86.8	219	122	41	0.90
CL65x95FD	104	23.5	30.8	34.8	42.8	M8x12	3.33	104	246	137	41	0.96
CL70x110FD	120	28	36.5	41.0	51.0	M10 x10	4.80	137	247	132	82	1.70
CL75x115FD	125	28	36.5	41.0	51.0	M10 x10	5.10	137	230	126	82	1.79
CL80x120FD	130	28	36.5	41.0	51.0	M10 x12	6.57	165	260	145	82	1.89
CL85x125FD	135	28	36.5	41.0	51.0	M10 x12	6.96	165	244	139	82	1.98
CL90x130FD	140	28	37.5	43.0	53.0	M10 x12	7.45	165	241	134	82	2.15
CL95x135FD	145	28	37.5	43.0	53.0	M10 x14	9.11	193	267	151	82	2.24
CL100x145FD	155	34	44.0	50.0	60.0	M10 x15	10.30	207	218	123	82	3.07
CL110x155FD	167	34	44.0	50.0	60.0	M10 x15	11.40	207	198	116	82	3.35
CL120x165FD	177	34	44.0	50.0	60.0	M10 x18	14.90	248	218	130	82	3.59
CL130x180FD	195	38	50.0	57.0	69.0	M12 x15	19.60	301	214	129	142	5.04
CL140x190FD	205	38	50.0	57.0	69.0	M12 x15	21.10	301	198	123	142	5.38
CL150x200FD	215	38	50.0	58.0	70.0	M12 x18	27.00	361	221	140	142	5.81

# CAPT-LOCKS

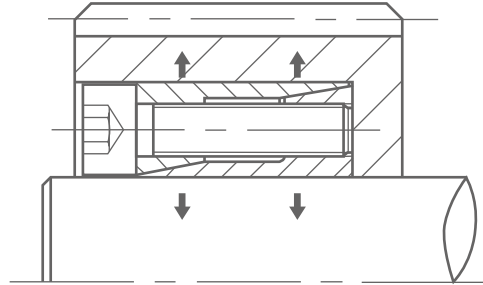

Locking assembly type FAR, bores from 5 to 50mm

- Simple structure
- Ideal power distribution shaft and hub
- Large clamping range
- Good centering ability and cyclic running
- No special tools needed
- No automatic locking
- High transmitted torque
- Shaft and hub up to precision h9-H9
- Shaft and hub without special cyclic tolerances
- Easy assembly & disassembly

**Fits surface**

By the special structure of the FAR type locking assembly even rough fits can be bridged with excellent centering ability Shaft and hub in qualities up to h9-H9. Surface roughness for shaft and hub is lower than 12mm.

**Assembly**

You can easily insert locking assembly and then get it greased, no need MoS2 Tighten screws oppositely and turn by 180° in several stages upto indicated torque.

**Important**

The locking assembly must be inserted into the drilling at least by measure "12".

**Disassembly**

Loosen screws oppositelg.

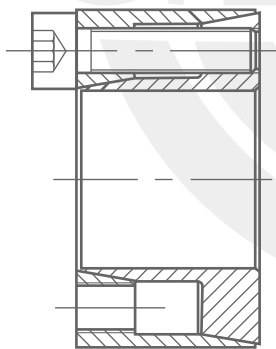

## FAR CAPT-LOCKS

Nomenclature for CAPT-LOCKS FAR

CL 5 X 16 FAR

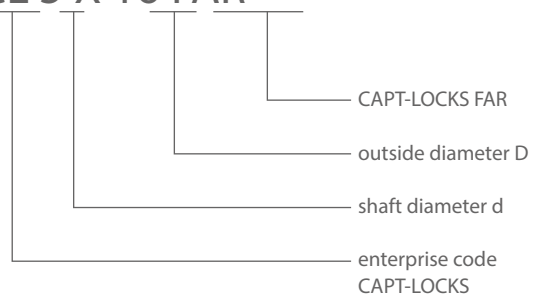



# CAPT-LOCKS

# FAR

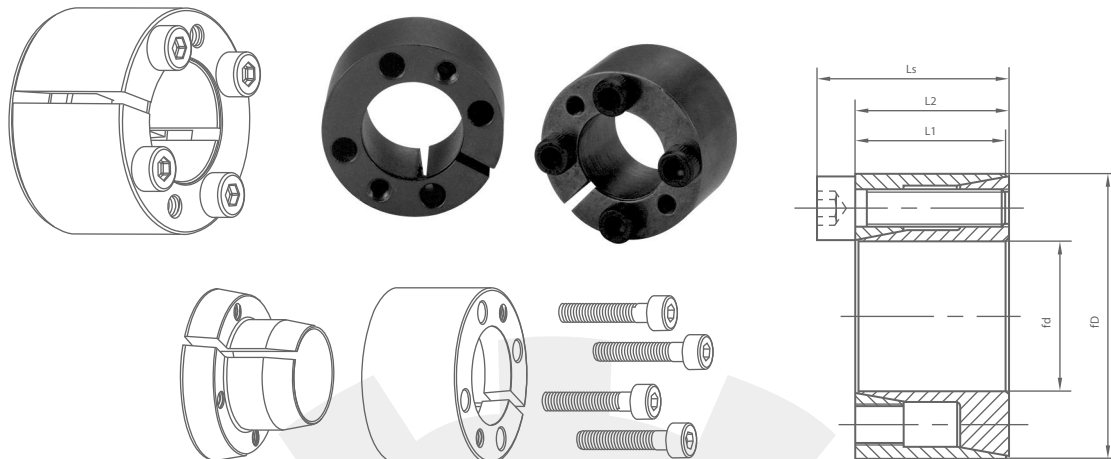

## FAR CAPT-LOCKS<sup>®</sup>

Catalog dxD	Fundamental dimensions			Sizes x N	Rated load		Ps Mpa	Ph Mpa	Ma N.m	G Kg
	L1	L2	Ls		Ft(Kn)	Mt(N.m)				
CL5x16FAR	10.5	11	13.5	M2.5x3	2	6	150	55	1.2	0.012
CL6x16FAR	10.5	11	13.5	M2.5x3	3	9	184	69	1.2	0.012
CL6.35x16FAR	10.5	11	13.5	M2.5X3	3	10	173	69	1.2	0.012
CL7x17FAR	10.5	11	13.5	M2.5x3	3	11	157	65	1.2	0.013
CL8x18FAR	10.5	11	13.5	M2.5x3	3	12	138	61	1.2	0.015
CL9x20FAR	12.5	13	15.5	M2.5x4	4	18	138	62	1.2	0.02
CL9.53x20FAR	12.5	13	15.5	M2.5x4	4	19	130	62	1.2	0.02
CL10x20FAR	12.5	13	15.5	M2.5x4	4	20	124	62	1.2	0.019
CL11x22FAR	12.5	13	15.5	M2.5X4	4	22	113	56	1.2	0.024
CL12x22FAR	12.5	13	15.5	M2.5X4	4	24	104	56	1.2	0.022
CL14x24FAR	16.5	17	20	M3x4	6	42	99	53	2.1	0.039
CL15x28FAR	16.5	17	20	M3x4	6	44	93	50	2.1	0.044
CL16x32FAR	16.5	17	21	M4x4	10.4	83	152	76	4.9	0.067
CL17x35FAR	20.5	21	25	M4x4	10.4	88	116	56	4.9	0.09
CL18x35FAR	20.5	21	25	M4x4	10.4	93	109	56	4.9	0.087
CL19x35FAR	20.5	21	25	M4x4	10.4	99	104	56	4.9	0.083
CL20x38FAR	20.5	21	26	M5x4	17	170	161	85	10	0.10
CL22x40FAR	20.5	21	26	M5x4	17	187	146	80	10	0.11
CL24x47FAR	25	26	32	M6x4	24	287	153	78	17	0.20
CL25x47FAR	25	26	32	M6x4	24	299	147	78	17	0.19
CL25.4x47FAR	25	26	32	M6x4	24	304	144	78	17	0.18
CL28x50FAR	25	26	32	M6x6	36	503	196	110	17	0.22
CL30x55FAR	25	26	32	M6x6	36	539	183	100	17	0.27
CL32x55FAR	25	26	32	M6x6	36	575	172	100	17	0.25
CL35x60FAR	30	31	37	M6x8	48	838	176	102	17	0.36
CL38x65FAR	30	31	37	M6x8	48	910	162	95	17	0.43
CL40x65FAR	30	31	37	M6x8	48	958	154	95	17	0.40
CL42x75FAR	35	36	44	M8x6	66.3	1394	175	98	41	0.67
CL45x75FAR	35	36	44	M8x6	66.3	1493	163	98	41	0.63
CL48x80FAR	35	36	44	M8x8	88.5	2124	204	122	41	0.74
CL50x80FAR	35	36	44	M8x8	88.5	2212	196	122	41	0.70

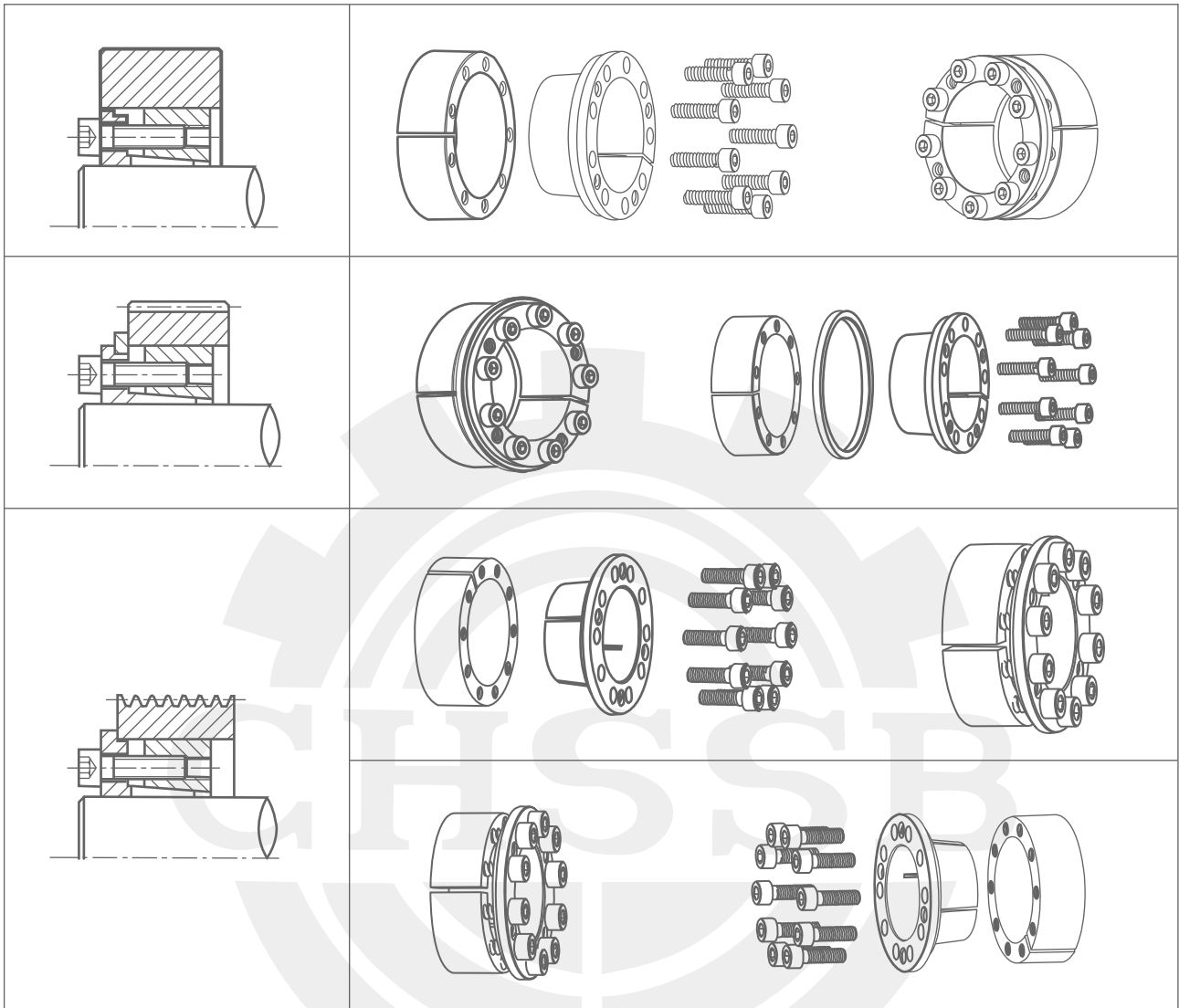

**Key elements for designing and calculation (FE.FA.FB)**

1. Determine max torque needed and max axial load

2. Calculate synthetic load and transmitted torque

$$M_{t \max} = \frac{30000H}{p \cdot n} \cdot K \text{ (N m)}$$

$$F_{t \max} = F_t \cdot K$$

H--Transmission power KW

n--rotational speed r/min

K--coefficient needed

Sheet for coefficient needed, K

$$M = \sqrt{M_{t^2} - \left(\frac{d}{2} \cdot F_t\right)^2}$$

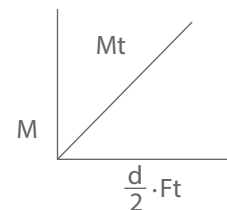

No shock load, transmitting with little inertia	1.5 – 2.5
Slight shock load, transmitting with middle inertia	2.0 – 4.0
Big shock load, transmitting with heavy inertia	3.0 – 5.0

M--Required transmitted torque N.M

Mt--CAPT lock rated transmitted torque N.m

Ft--Rated axial force N

d--Transmission shaft diameter mm

$M_t \geq M$ , can be used.

$M_t < M$ , need bigger type of CAPT lock or to be installed by two CAPT locks or more together

# CAPT-LOCKS

## Key elements for designing and calculation B

### 3. Calculation for the hub diameter

$$Da \geq D \sqrt{\frac{\sigma_b + Ka \cdot Ph}{\sigma_b - Ka \cdot Ph}}$$

$$dB \leq d \sqrt{\frac{\sigma_b - 2xPs \cdot K3}{\sigma_b}}$$

Da--outside diameter of hub mm  
 D--inside diameter of hub mm  
 Ph--surface pressure on hub/Mpa  
 $\sigma_b$ --tensile strength of material  
 Ka--It should be 0.6 for single CAPT LOCK, it will be 0.8 when two CAPT LOCKS or more are installed together

dB--inside diameter of hollow shaft mm  
 d--outside diameter of hollow shaft mm  
 $\sigma_b$ --tensile strength of shaft material Mpa  
 Pf--pressure on the surface of shaft Mpa  
 K3--coefficient=0.6

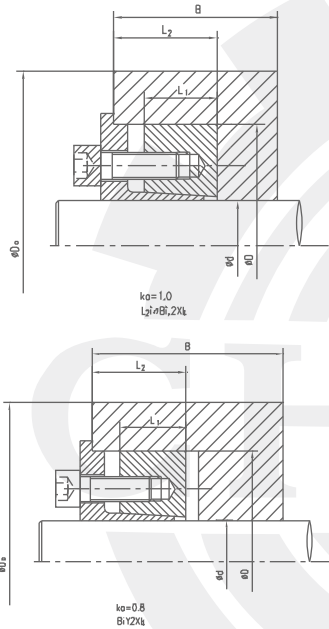

### 6. Installation for CAPT-LOCKS

Cleaning the CAPT-LOCKS, then install it into corresponding position of hub and shaft(Ref Drawing A). Then acc. to the order in Drawing B. Tighten the bolts in turn, the bolts should be tightened step by step in 3 to 4 times up to specified rated torque.

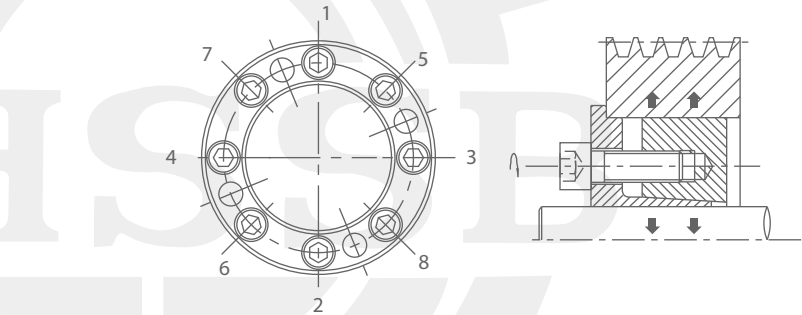

conceptual diagram for in installation

### 4. Determination for the surface roughness and dimension

Fitting section	Ra(um) Surface roughness	Dimension precision
Shaft diameter d	1.6/ ▽	h8
Bore diameter D	1.6/ ▽	H8

After installing the CAPT locks correctly, the radial and axial run out should be inspected according to  $A \leq 0.05\text{mm}$  and  $B \leq 0.002$ .

### 5. Calculation for the inside diameter of hollow shaft

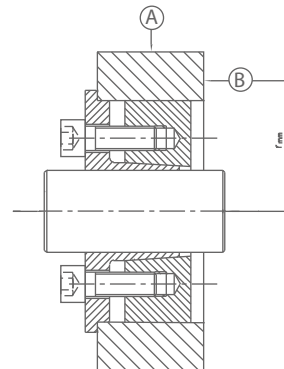
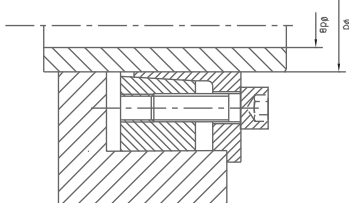

# CAPT-LOCKS

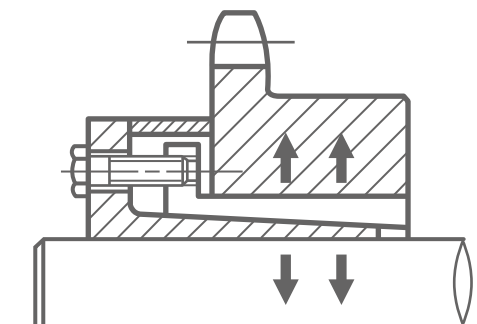
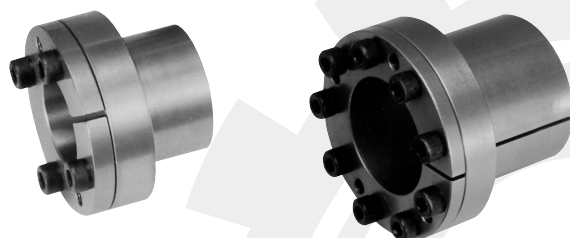
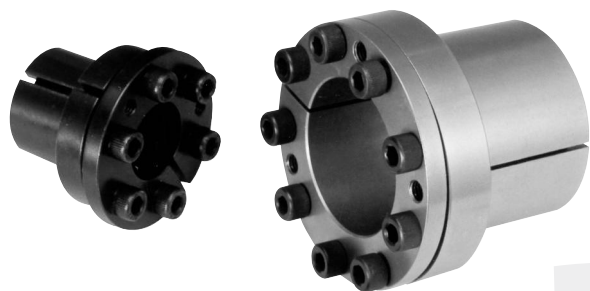

suit for shaft diameter  
f6~f130mm

As the specified data between outside diameter D and the inner bore d for CAPT LOCK Type T has a very small difference, and it suit for the connection with the shaft in a medium or small diameter, specially for the connection in a small space between the inner bore of hub and shaft.

The working fundation for CAPT lock Type T is that the inner ring with flange and taper surface is fixed with the outside ring with taper bore by relevant tightening bolt and tighten the bolt to make the inner ring move axially. The emerged pressure and friction in radius effect the connection between hub and shaft.

There is a locating ring between the inner ring and outer ring to use for locating and sealing.

Type T CAPT lock is composed by an inner ring, an outer ring, a locating ring and relevant tightening bolt which have characteristics for simple structure, self centered, good concentricity, good sealing, dust-proof and water-proof etc.

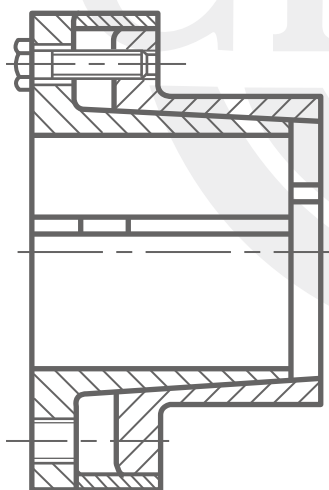

Nomenclature for CAPT-LOCK T

CL 50 X 60 T

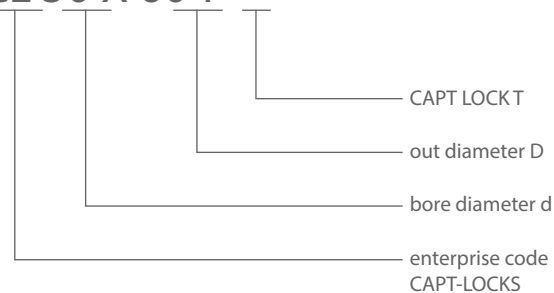

**T** CAPT-LOCKS

# CAPT-LOCKS

# T

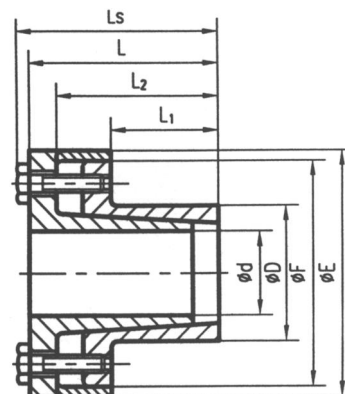
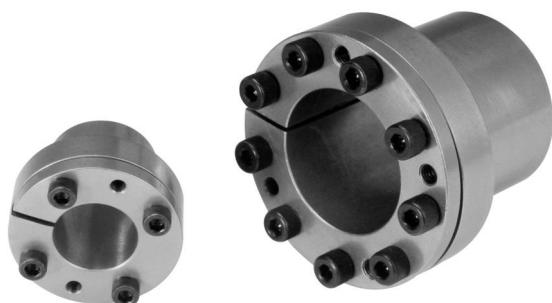

## T CAPT-LOCKS

Catalog dxD	Fundamental dimensions						SizesxN	Rated load		Ps Mpa	Ph Mpa	Ma N.m	G Kg
	E	F	L1	L2	L	Ls		Ft(Kn)	Mt(Kn.m)				
CL6x14T	25	23	10	18,5	21	24	M3x3	4.2	0.012	185	80	2	0.15
CL7x15T	27	24	12	22	25	29	M4x3	7.4	0.025	235	110	4.9	0.15
CL8x15T	27	24	12	22	25	29	M4x3	7.4	0.029	205	110	4.9	0.16
CL9x16T	28	25	14	23	26	30	m4x4	9.4	0.044	205	115	4.9	0.16
CL10x16T	28	25	14	23	26	30	M4x4	9.8	0.049	185	115	4.9	0.17
CL11x18T	32	28	14	23	26	30	M4x4	9.8	0.053	170	105	4.9	0.17
CL12x18T	32	28	14	23	26	30	M4x4	9.8	0.058	160	105	4.9	0.18
CL13x23T	38	33	14	23	26	30	M4x4	9.8	0.063	140	80	4.9	0.19
CL14x23T	38	33	14	23	26	30	M4x4	9.8	0.068	130	80	4.9	0.2
CL15x24T	45	40	16	29	36	42	M6x3	17	0.127	185	115	17	0.21
CL16x24T	45	40	16	29	36	42	m6x3	17	0.136	175	115	17	0.23
CL17x26T	47	42	18	31	38	44	M6x4	2	0.18	190	125	17	0.25
CL18x26T	47	42	18	31	38	44	M6x4	22	0.20	180	125	17	0.27
CL19x27T	49	43	18	31	38	44	M6x4	22	0.21	170	120	17	0.29
CL20x28T	50	44	18	31	38	44	M6x4	22	0.22	160	115	17	0.30
CL22x32T	54	48	25	38	45	51	M6x4	22	0.25	115	80	17	0.38
CL24x34T	56	50	25	38	45	51	M6x4	22	0.27	105	75	17	0.41
CL25x34T	56	50	25	38	45	51	M6x4	22	0.25	100	75	17	0.45
CL28x39T	61	55	25	38	45	51	M6x6	33	0.465	135	97	17	0.47
CL30x41T	62	57	25	38	45	51	M6x6	33	0.51	127	90	17	0.48
CL32x43T	65	59	25	38	45	51	M6x6	33	0.54	120	90	17	0.52
CL35x47T	69	62	32	45	52	58	M6x8	45	0.79	105	80	17	0.63
CL38x50T	72	66	32	45	52	58	M6x8	45	0.86	100	75	17	0.67
CL40x53T	75	69	32	45	52	58	M6x8	45	0.90	95	70	17	0.73
CL42x55T	78	71	32	45	52	58	M6x8	45	0.95	90	70	17	0.78
CL45x59T	86	80	45	62	70	78	M8x8	84	1.89	110	85	41	1.23
CL48x62T	87	81	45	62	70	78	M8x8	84	2.01	105	80	41	1.24
CL50x65T	92	84	45	62	70	78	M8x8	84	2.10	100	75	41	1.40
CL55x71T	98	92	55	72	80	88	M8x9	94	2.60	85	65	41	1.70
CL60x77T	104	98	55	72	80	88	M8x9	94	2.84	75	60	41	1.90
CL65x84T	111	105	55	72	80	88	M8x9	94	3.07	70	55	41	2.21
CL70x90T	119	113	65	86	96	106	M10x9	150	5.25	90	70	83	3.05
CL75x95T	126	119	65	86	96	106	M10x9	150	5.60	80	65	83	3.32
CL80x100T	131	125	65	86	96	106	M10x12	200	8.02	100	80	83	3.50
CL85x106T	137	131	62	86	96	106	M10x12	200	8.50	95	75	83	3.81
CL90x112T	144	137	65	86	96	106	M10x12	200	9.00	90	75	83	4.20
CL95x120T	149	142	65	86	96	106	M10x14	230	11.0	100	80	83	4.75
CL100x125T	154	147	65	86	96	106	M10x18	300	15.0	120	95	83	5.46
CL110x140T	180	172	90	114	128	140	M12x12	290	16.0	80	65	145	6.05
CL120x155T	198	187	90	114	128	140	M12x12	290	17.5	70	55	145	7.18
CL130x165T	208	197	90	114	128	140	M12x16	384	25.0	90	70	145	8.03

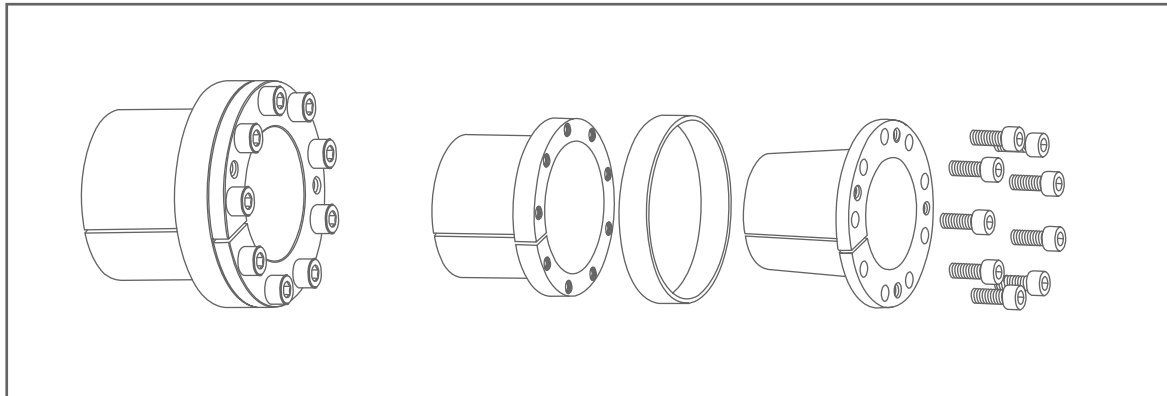

### Key elements for designing and calculation T

1. Determine max torque needed and max axial load

$$Mt_{max} = \frac{30000H}{p \cdot n} \cdot K \text{ (N m)}$$

$$Ft_{max} = Ft \cdot K$$

H--Transmission power KW

n--rotational speed r/min

K--coefficient needed

Sheet for coefficient needed, K

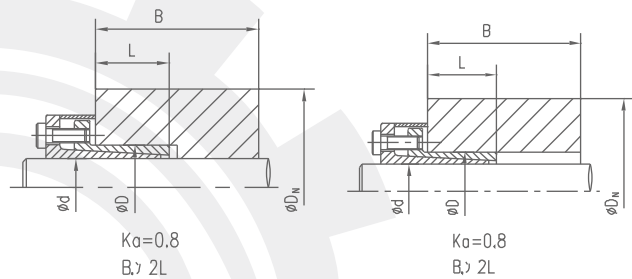

No shock load, transmitting with little inertia	1.5 - 2.5
Slight shock load, transmitting with middle inertia	2.0 - 4.0
Big shock load, transmitting with heavy inertia	3.0 - 5.0

Da--outside diameter of hub mm

D--inside diameter of hub mm

Ph--surface pressures on hub Mpa

$\sigma_b$ --tensile strength of material

Ka--It should be 0.6 for single CAPT lock, it will be 0.8 when two CAPT locks or more are installed together

2. Calculate synthetic load and transmitted torque

$$M = \sqrt{Mt^2 - \left(\frac{d}{2} \cdot Ft\right)^2}$$

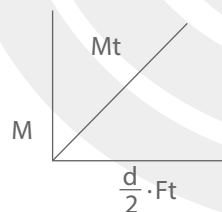

M--Required transmitted torque N.M

Mt--CAPT lock rated transmitted torque N.m

Ft--Rated axial force N

d--Transmission shaft diameter mm

$Mt \geq M$ , can be used.

$Mt < M$ , need bigger type of CAPT lock or to be installed by two CAPT locks or more together

4. Calculation for the inside diameter of hollow shaft

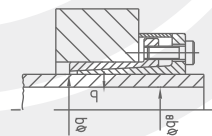

$$dB \leq d \sqrt{\frac{\sigma_b - 2xPs \cdot K3}{\sigma_b}}$$

dB--inside diameter of hollow shaft mm

d--outside diameter of hollow shaft mm

6b--tensile strength of shaft material Mpa

Ps--pressure on the surface of shaft Mpa

3. Calculation for the hub diameter

$$Da \geq D \sqrt{\frac{\sigma_b + Ka \cdot Ph}{\sigma_b - Ka \cdot Ph}}$$

5. Settlement for the surface roughness and dimension tolerance

Fitting section	Ra(um) Surface roughness	Dimension precision
Shaft diameter d	1.6/ $\sqrt{\quad}$	h8
Bore diameter D	1.6/ $\sqrt{\quad}$	H8

6. Installation and disassembling for CAPT-LOCKS Type T.

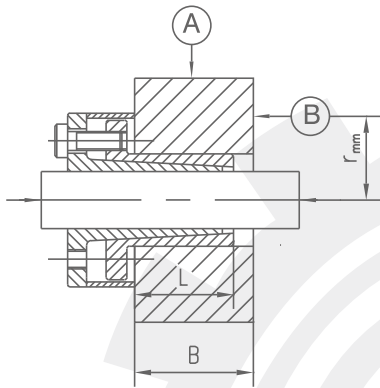
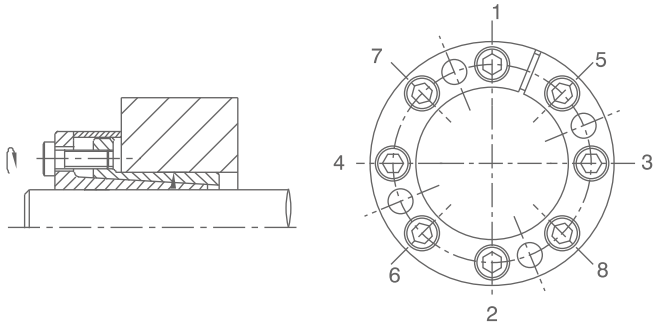

Tighten the bolts one by one as shown in picture 1 and 2. and reach the specified torque step by step. After the correct installation, the run out should be inspected as shown in picture 3. the run out A should be  $0.05\text{mm}$  and B should be  $0.002R\text{mm}$ .

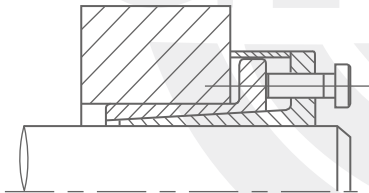

When disassembling, take off all the tightening bolts and insert the unloading bolts into the unloading tap holes and tighten them. By doing this, CAPT lock can be loosen and be separated with hub and shaft.

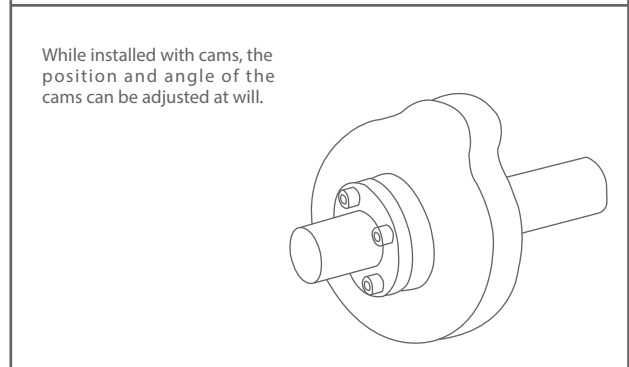
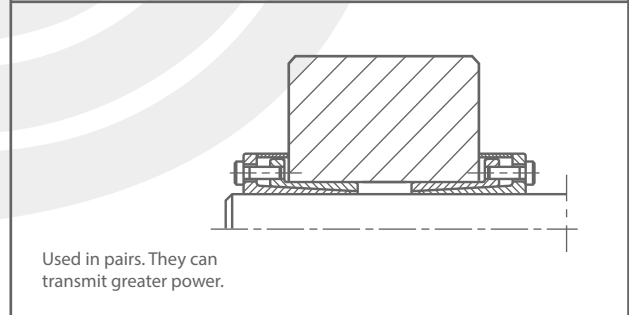
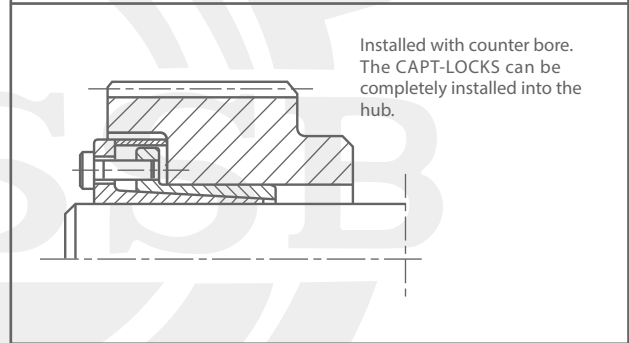
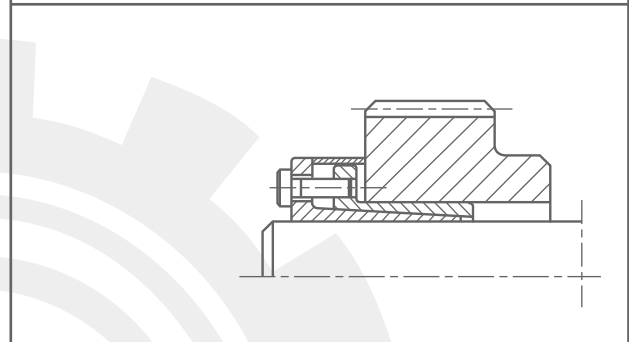
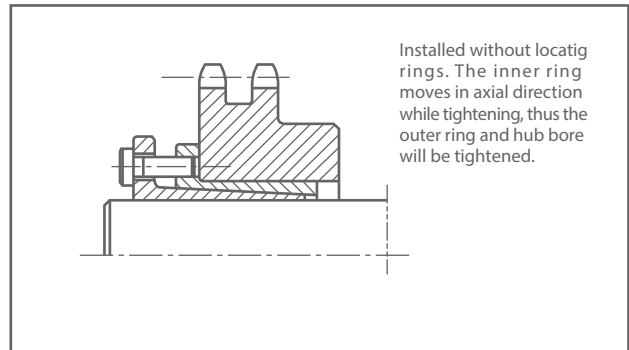
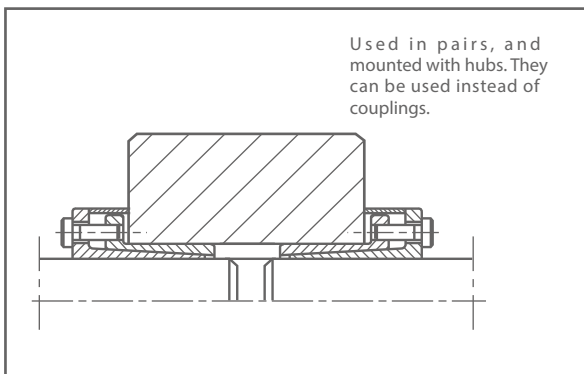

# CAPT-LOCKS

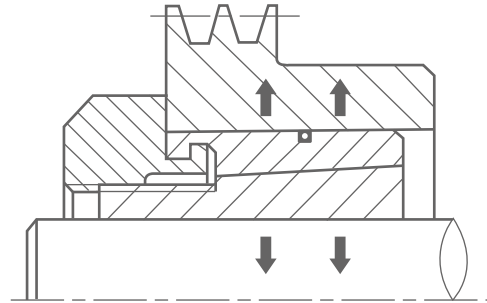

suit for shaft:  
f5~f75mm

When assembling CAPT-LOCKS ML/ML-B, the outer taper ring will be moved in axial direction following the turning of screw nuts. Due to the function on the taper surfaces of both inner and outer rings, extrusion force will be occurred on the connection surface of shaft and hub, ie, two pressing forces, P and P' in the radius direction will be formed. Then the shaft and components can be assembled firmly by the frictional force between shaft and hub to the two pressing forces on them from P and P' at the same time. After assembling, no need to worry about any loose caused by the shaking as the two taper surface are strongly self-locked and a very strong frictional force on them exists from beginning to end. When inner ring disassembling, first loose screw nuts in opposite direction and will be separated with the outer ring. The disassembling can be easily finished.

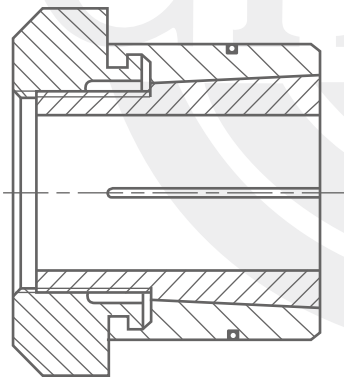

The characteristics for the usage of CAPT-LOCKS type ML/ ML-B

- (1) easy on and easy off, self-centered, concentricity between hub and shaft can be ensured while assembling without any extra positioning equipment;
- (2) Wide scope for selecting, a different CAPT-LOCKS type ML/ML-B can be chosen according to need, the smallest width can be 10mm;
- (3) Very convenient for assembling and disassembling. Only by tightening screw nuts, assembling can be easily finished in a very short time. On the other hand, it can be disassembled easily only by loosening the screw nuts in opposite direction.
- (4) Simple construction, without complicated processing and occupy much less space.

Nomenclature for CAPT-LOCKS ML

CL 17 X 36 ML

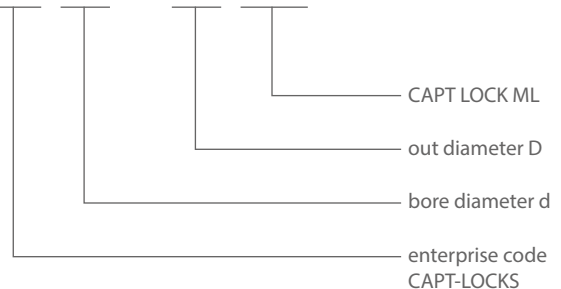

**ML** CAPT-LOCKS



# CAPT-LOCKS

# ML

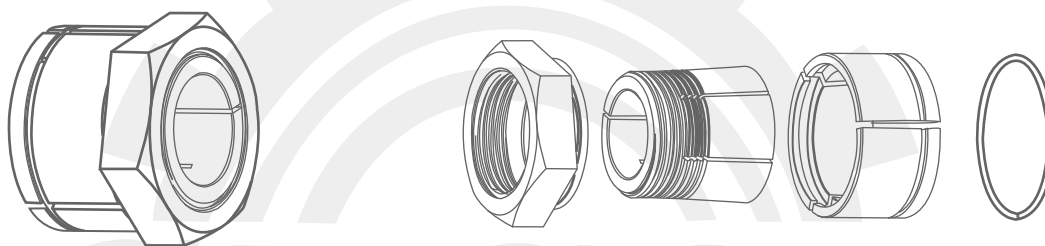
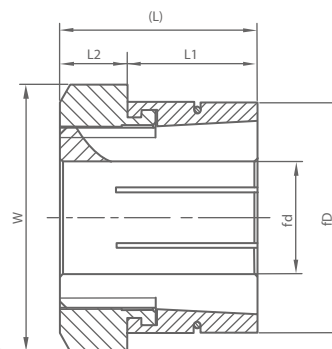

## ML CAPT-LOCKS<sup>®</sup>

Catalog	Fundamental dimensions				Rated load		Ps	Ph	Ma	G
	L	L1	L2	W	Mt(Kn.m)	Ft(Kn)	Mpa	Mpa	N.m	Kg
CL5x16ML	15	10	5	17	0.007	2.65	314	45	9.10	0.020
CL6x16ML	15	10	5	17	0.008	2.65	297	45	9.10	0.019
CL7x21ML	21	14	7	22	0.015	6.57	295	60	19.9	0.049
CL8x21ML	21	14	7	22	0.018	6.57	270	60	19.9	0.047
CL9x21ML	21	14	7	22	0.020	6.57	245	60	19.9	0.045
CL10x24ML	22	14	8	24	0.026	8.43	285	68	25.5	0.061
CL11x24ML	22	14	8	24	0.028	8.43	255	68	25.5	0.058
CL12x24ML	22	14	8	24	0.031	8.43	235	68	25.5	0.055
CL14x31ML	27	17	10	32	0.083	16.10	295	81	80	0.130
CL15x31ML	27	17	10	32	0.090	16.10	270	81	80	0.130
CL16x31ML	27	17	10	32	0.096	16.10	250	81	80	0.120
CL17x36ML	33	21	12	36	0.145	22.80	235	80	136	0.200
CL18x36ML	33	21	12	36	0.155	22.80	295	80	136	0.190
CL19x36ML	33	21	12	36	0.163	22.80	290	80	136	0.190
CL20x41ML	35	23	12	41	0.245	24.90	270	71	230	0.270
CL22x41ML	35	23	12	41	0.274	24.90	260	71	230	0.250
CL24x41ML	35	23	12	41	0.294	24.90	270	71	230	0.230
CL25x46ML	37	25	12	46	0.365	30.10	245	70	300	0.330
CL28x46ML	37	25	12	46	0.408	30.10	260	70	300	0.300
CL30x50ML	41	28	13	50	0.446	30.10	250	66	330	0.410
CL32x50ML	41	28	13	50	0.475	30.10	280	66	330	0.370

# CAPT-LOCKS

# ML-B

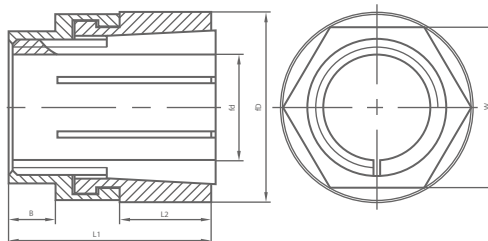
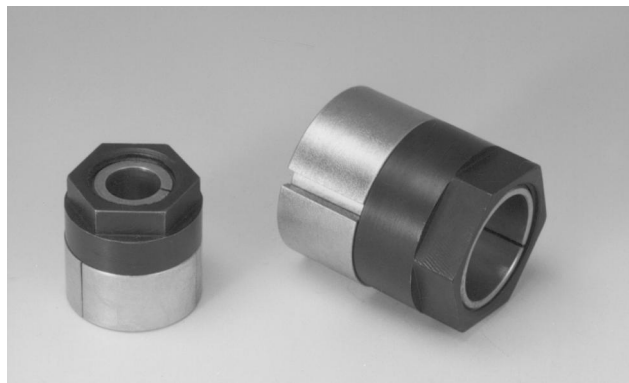

## ML-B CAPT-LOCKS®

Catalog dxD	Fundamental dimensions				Rated load		Ph	Ma	G
	L1	L2	W	B	Mt(Kn)	Ft(N.m)	Mpa	N.m	Kg
CL5x16ML-B	19	9.5	13	3	0.01	3.20	36	14.1	0.014
CL6x16ML-B	19	9.5	13	3	0.013	3.42	36	14.1	0.013
CL7x19ML-B	22	11	16	3	0.013	3.43	26	17	0.028
CL8x19ML-B	22	11	16	3	0.015	3.97	26	17	0.027
CL9x19ML-B	22	11	16	3	0.018	4.06	26	17	0.026
CL10x22.5ML-B	25.5	12.5	19	5	0.023	4.15	19	23.1	0.042
CL11x22.5ML-B	25.5	12.5	19	5	0.025	4.22	19	23.1	0.041
CL12x22.5ML-B	25.5	12.5	19	5	0.028	4.30	19	23.1	0.040
CL14x25.5ML-B	28.5	16	22	5	0.046	4.40	13	38	0.056
CL15x25.5ML-B	28.5	16	22	5	0.049	4.43	13	38	0.055
CL16x25.5ML-B	28.5	16	22	5	0.053	4.46	13	38	0.054
CL15x38ML-B	38	19	32	8	0.12	13.6	76	136	0.231
CL16x38ML-B	38	19	32	8	0.13	15.0	76	136	0.230
CL17x38ML-B	38	19	32	8	0.14	17.0	76	136	0.229
CL18x38ML-B	38	19	32	8	0.15	18.3	76	136	0.228
CL19x38ML-B	38	19	32	8	0.16	19.9	76	136	0.226
CL20x45ML-B	47.5	21.5	38	11	0.23	21.4	65	230	0.31
CL22x45ML-B	47.5	21.5	38	11	0.26	24.5	65	230	0.30
CL24x45ML-B	47.5	21.5	38	11	0.29	27.5	65	230	0.29
CL25x45ML-B	47.5	21.5	38	11	0.30	28.7	65	230	0.29
CL28x51ML-B	57	25.5	46	13	0.41	32.6	54	330	0.45
CL30x51ML-B	57	25.5	46	13	0.44	35.4	54	330	0.44
CL32x51ML-B	57	25.5	46	13	0.47	38.2	54	330	0.43
CL34x60.5ML-B	70	38	50	14	0.49	41.0	45	390	0.77
CL35x60.5ML-B	70	38	50	14	0.51	42.4	45	390	0.76
CL36x60.5ML-B	70	38	50	14	0.52	43.8	45	390	0.75
CL38x60.5ML-B	70	38	50	14	0.55	46.6	45	390	0.73
CL40x67ML-B	79.5	43	60	14.5	0.63	49.7	38	460	1.05
CL42x67ML-B	79.5	43	60	14.5	0.65	53.3	38	460	1.00
CL45x73ML-B	90.5	51	65	16	0.71	57.5	29	540	1.36
CL48x73ML-B	90.5	51	65	16	0.75	62.9	29	540	1.33
CL50x73ML-B	90.5	51	65	16	0.82	65.7	29	540	1.31
CL55x80ML-B	95	54	70	16	1.24	67.8	24	810	2.13
CL60x86ML-B	98.5	57	75	17.5	1.41	68.7	20	910	2.27
CL65x92ML-B	103	60.5	80	17.5	1.51	69.5	17	980	2.68
CL70x92ML-B	103	60.5	80	7.5	1.62	70.4	17	980	2.66
CL75x100ML-B	108	63.5	90	19	1.63	71.5	16	990	2.75

# CAPT-LOCKS

# ML-C

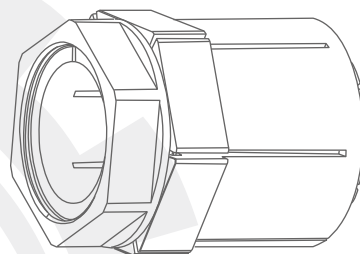
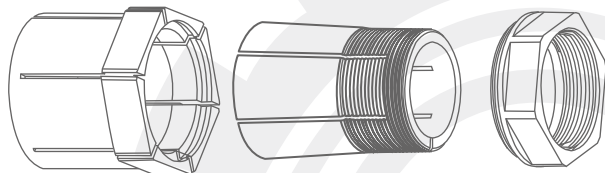
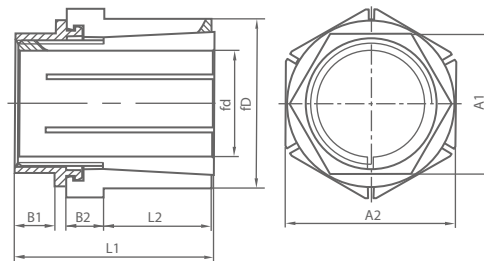

## ML-C CAPT-LOCKS<sup>®</sup>

Catalog	Fundamental dimensions						Rated loadPh		Ps	Ma	G	Kg
	dxD	L1	L2	A1	A2	B1	B2	Mt(Kn.m)				
CL15x38ML-C	38	19	32	38.1	8	8	0.18	13.38	76	314	196	0.23
CL16x38ML-C	38	19	32	38.1	8	8	0.19	14.70	76	297	196	0.22
CL17x38ML-C	38	19	32	38.1	8	8	0.20	16.66	76	295	196	0.21
CL18x38ML-C	38	19	32	38.1	8	8	0.21	17.98	76	270	196	0.20
CL19x38ML-C	38	19	32	38.1	8	8	0.22	19.60	76	245	196	0.19
CL20x45ML-C	47.5	21.5	38	44.5	11	9.5	0.25	20.97	65	285	240	0.31
CL22-45ML-C	47.5	21.5	38	44.5	11	9.5	0.27	23.97	65	255	240	0.30
CL24x45ML-C	47.5	21.5	38	44.5	11	9.5	0.30	26.97	65	235	240	0.29
CL25x45ML-C	47.5	21.5	38	44.5	11	9.5	0.31	28.13	65	295	240	0.28
CL28x51ML-C	57	25.5	46	50.8	13	14.5	0.34	31.96	54	270	275	0.45
CL30x51ML-C	57	25.5	46	50.8	13	14.5	0.36	34.69	54	250	275	0.43
CL32x51ML-C	57	25.5	46	50.8	13	14.5	0.38	37.43	54	235	275	0.41
CL34x60.5ML-C	70	38	50	60.3	14	13	0.42	40.18	45	295	330	0.77
CL35x60.5ML-C	70	38	50	60.3	14	13	0.43	41.55	45	290	330	0.75
CL36x60.5ML-C	70	38	50	60.3	14	13	0.44	42.92	45	270	330	0.74
CL38x60.5ML-C	70	38	50	60.3	14	13	0.47	45.67	45	260	330	0.72
CL40x67ML-C	79.5	43	60	66.7	14.5	17.5	0.57	48.71	38	270	420	1.05
CL42x67ML-C	79.5	43	60	66.7	14.5	17.5	0.59	52.23	38	245	420	1.02
CL45x73ML-C	90.5	51	65	73	16	19	0.80	56.35	29	260	585	1.36
CL48x73ML-C	90.5	51	65	73	16	19	0.85	61.64	29	250	585	1.33
CL50x73ML-C	90.5	51	65	73	16	19	0.88	64.38	29	280	585	1.31
CL55x80ML-C	95.3	54	70	79.4	16	20.5	1.04	66.44	24	260	680	2.13
CL60x86ML-C	98.4	57.2	75	85.7	17.5	19	1.06	67.32	20	250	360	2.27
CL65x92ML-C	103.2	60.3	82	92.1	17.5	20.5	1.33	68.11	17	260	880	2.68
CL70x92ML-C	103.2	60.3	82	92.1	17.5	20.5	1.45	69.00	17	250	880	2.58
CL75x100ML-C	108	63.5	90	98.4	19	20.5	1.61	70.10	16	260	980	2.72

### Key elements for designing and calculation (ML,ML-B,ML-C)

1. Determine max torque needed and max axial load

$$M_{t \max} = \frac{30000H}{p \cdot n} \cdot K \text{ (N m)}$$

$$F_{t \max} = F_t \cdot K$$

H--Transmission power KW  
 n--rotational speed r/min  
 K--coefficient needed  
 Used coefficient sheet for K

No shock load, transmitting with little inertia	1.5 – 2.5
Slight shock load, transmitting with middle inertia	2.0 – 4.0
Big shock load, transmitting with heavy inertia	3.0 – 5.0

2. Calculate synthetic load and transmitted torque

$$M = \sqrt{M_t^2 - \left(\frac{d}{2} \cdot F_t\right)^2}$$

M--Required transmitted torque N.M  
 Mt--CAPT lock rated transmitted torque N.m  
 Ft--Rated axial force N  
 d--Transmission shaft diameter mm

Mt ≥ M, can be used.  
 Mt < M, need bigger type of CAPT lock or to be installed by two CAPT locks or more together

3. Calculation for the hub diameter

$$D_a \geq D \sqrt{\frac{\sigma_b + K_a \cdot P_h}{\sigma_b - K_a \cdot P_h}}$$

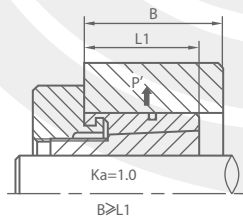

Da--outside diameter of hub mm  
 D--inside diameter of hub mm  
 Ph--surface pressure on hub Mpa  
 $\sigma_b$ --tensile strength of material Mpa

4. Calculation for the inside diameter of hollow shaft

$$d_B \leq d \sqrt{\frac{\sigma_b - 2 \times P_f \cdot K_3}{\sigma_b}}$$

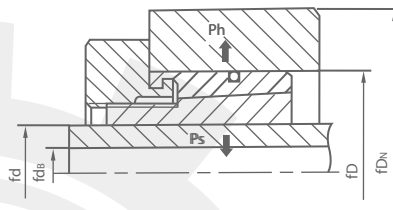

dB--inside diameter of hollow shaft mm  
 d--outside diameter of hollow shaft mm  
 b--tensile strength of shaft material Mpa  
 Ps--pressure on the surface of shaft Mpa

5. Determine surface roughness and dimension tolerance

Fitting section	Surface roughness	Dimension precision
Shaft diameter d	1.6/	h8
Bore diameter D	1.6/	H8

6. Installation and disassembling for CAPT lock Type T.

After installing the CAPT locks correctly, the radial and axial run out should be inspected according to A ≤ 0.05mm and B 0.002R.

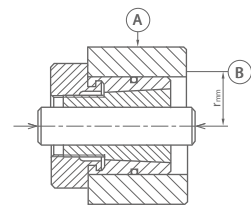

#### Conventional installation of ML CAPT-LOCKS

<p>Conventional installation</p>	<p>Used in pairs and mounted with hubs. They can be used instead of couplings</p>	<p>Used in pairs, thus greater power can be transmitted, for the usage of heavy load transmission</p>
----------------------------------	---	---

# CAPT-LOCKS

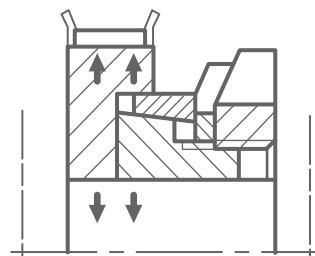
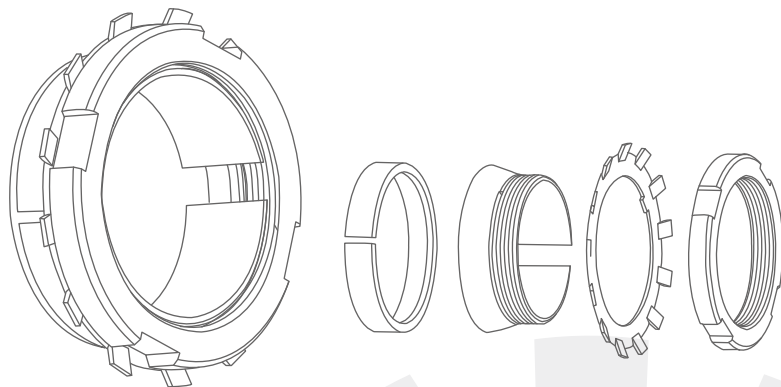

suit for shaft diameter  
f14-f70mm

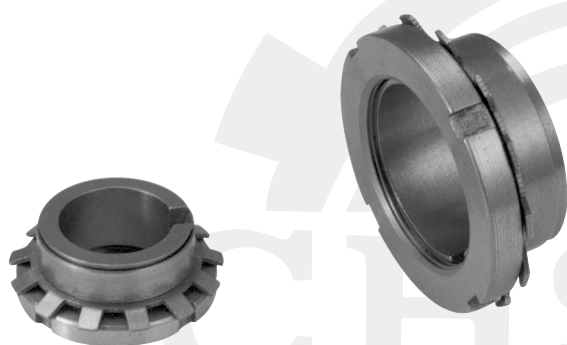

HL type CAPT locks are suitable for connection between medium or small diameter shaft and hubs. They can be self-centered installed and their concentricity is very high with a low production cost. The shaft diameter and the bore of hubs are both in straight line, so machining process is not very complicated.

The working principle of HL type CAPT locks is as following: twist the round nut on the inner hub with outer taper surface, making it move axially, press the outer ring with taper bore, pressure and friction cause the joint between the hubs and shafts together without key and clearance.

HL type CAPT locks can be installed with only one round nut. Twist the nut to tighten the hubs and shaft, lock the round nut by relevant washer, which can prevent Capt lock from moving axially and ensure the torque transmitted enough.

HL type Capt locks can be installed and used only if the axial length of the inner bore of hub is smaller than the dimension B of CAPT lock.

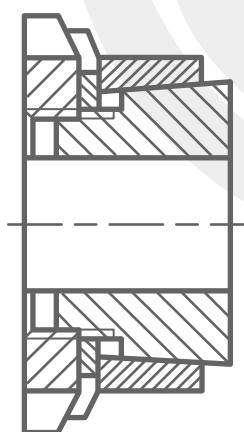

Nomenclature for CAPT-LOCKS HL

**CL 5 X 16 HL**

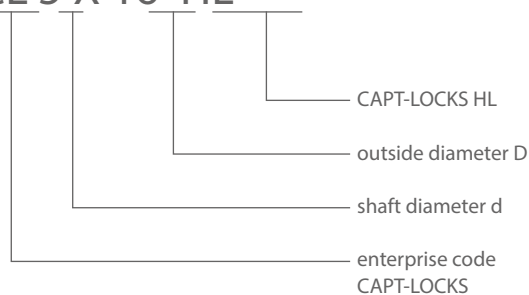

**HL** CAPT-LOCKS

# CAPT-LOCKS

# HL



## HL CAPT-LOCKS<sup>®</sup>

Catalog dxD	Fundamental dimensions			Locking nut		Rated load		Ps	Ph	G
	B	H	E	Sizes	Ma(N.m)	Ft(Kn)	Mt(Kn.m)	Mpa	Mpa	Kg
CL14x25HL	6.5	16.5	32	M20x1.0	95	5.1	0.038	200	110	0.06
CL15x25HL	6.5	16.5	32	M20x1.0	95	5.5	0.041	185	110	0.06
CL16x25HL	6.5	16.5	32	M20x1.0	95	5.45	0.043	174	110	0.06
CL17x26HL	6.5	16.5	32	M20x1.0	95	5.5	0.047	164	107	0.07
CL18x26HL	6.5	16.5	32	M22x1.0	95	5.4	0.049	155	107	0.07
CL18x30HL	6.5	18	38	M25x1.5	160	6.6	0.058	185	112	0.07
CL19x30HL	6.5	18	38	M25x1.5	160	6.6	0.062	176	112	0.08
CL20x30HL	6.5	18	38	M25x1.5	160	6.6	0.066	167	111	0.08
CL22x32HL	6.5	18	38	M25x1.5	160	6.6	0.073	152	105	0.09
CL24x35HL	6.5	18	45	M30x1.5	220	8.75	0.105	185	127	0.09
CL25x35HL	6.5	18	45	M30x1.5	220	8.8	0.11	178	127	0.09
CL28x36HL	6.5	18	45	M32x1.5	220	8.55	0.12	159	124	0.14
CL28x40HL	7	19.5	52	M35x1.5	340	10.6	0.149	188	141	0.15
CL30x40HL	7	19.5	52	M35x1.5	340	10.6	0.16	164	123	0.14
CL32x42HL	8	21.5	55	M36x1.5	340	10.6	0.17	154	117	0.16
CL35x45HL	8	21.5	58	M40x1.5	480	13.1	0.23	153	120	0.17
CL36x45HL	8	21.5	58	M40x1.5	480	13.3	0.24	149	120	0.16
CL38x48HL	8	21.5	62	M42x1.5	480	13.1	0.25	141	112	0.27
CL38x50HL	8	21.5	62	M42x1.5	480	13.1	0.25	141	112	0.28
CL40x50HL	10	24.5	65	M45x1.5	680	15.5	0.31	124	93	0.24
CL40x52HL	10	24.5	65	M45x1.5	680	15.5	0.31	120	93	0.26
CL42x55HL	10	24.5	68	M48x1.5	680	15.2	0.32	114	87	0.28
CL45x55HL	10	25.5	70	M50x1.5	870	17.7	0.4	122	96	0.30
CL45x57HL	10	25.5	70	M50x1.5	870	17.7	0.4	122	96	0.30
CL48x60HL	10	25.5	75	M55x2.0	970	20.8	0.5	135	105	0.36
CL50x60HL	10	25.5	75	M55x2.0	970	20.8	0.52	130	105	0.32
CL50x62HL	10	25.5	75	M55x2.0	970	20.8	0.52	130	105	0.32
CL55x65HL	12	27.5	80	M60x2.0	1100	22	0.61	103	84	0.38
CL55x68HL	12	27.5	80	M60x2.0	1100	22	0.61	103	84	0.38
CL56x68HL	12	27.5	80	M60x2.0	1100	22	0.62	101	82	0.39
CL60x70HL	12	28.5	85	M65x2.0	1300	26.6	0.8	113	93	0.43
CL60x73HL	12	28.5	85	M65x2.0	1300	26.6	0.8	113	93	0.43
CL63x79HL	14	30.5	92	M70x2.0	1600	31.1	0.98	107	86	0.47
CL65x79HL	14	30.5	92	M70x2.0	1600	31.1	1.01	104	86	0.50
CL70x84HL	14	31.5	98	M75x2.0	2000	35.4	1.24	110	92	0.65

# CAPT-LOCKS

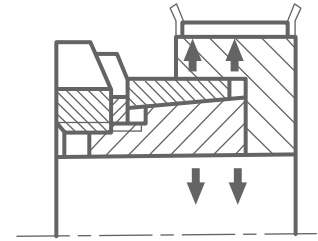
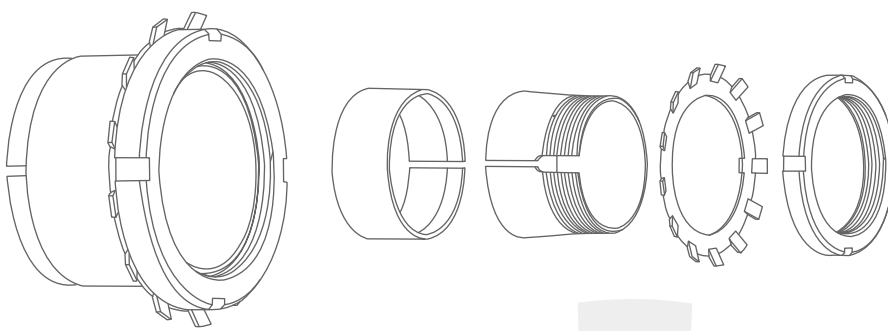

suit for shaft diameter  
metric:f14~f60mm

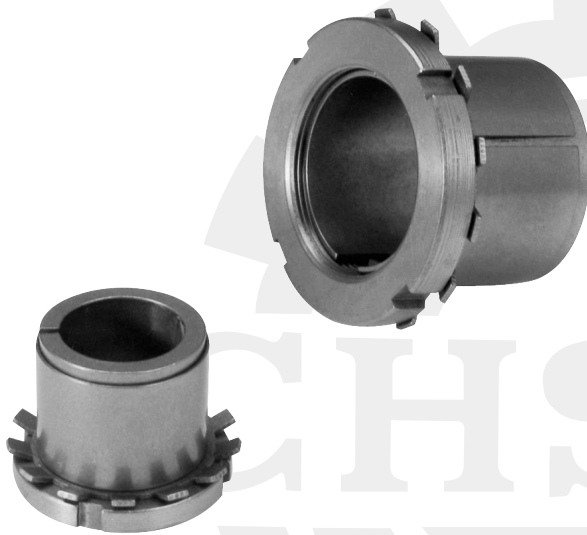

CAPT lock type HLL is the longer one for Type HL with a very good characteristics of anti lock. It can transfer a bigger torque due to a longer length. When the transmission can't be ensured by Type HL, Type HLL can be selected.

CAPT lock type HLL suit for the connection between medium or small shaft and hub. It is of self-centered. The inner bores for shaft and hub are both plain and so the machining is simple and price is very good.

The working principle for CAPT lock Type HLL is that tightening the round nut on the inner hub with outside taper surface to make the inner hub move axially. This will press the outer hub with taper bore and the pressure and friction emerged in radial effect the connection without key and slot between hub and shaft.

Only one round nut will be enough for the intallation. After tightening round nut and make the hub and shaft press each other. Then the round nut should be locked with the relevant washer to avoid CAPT lock move axially to ensure the reliability that rated torque can be transmitted.

Type HLL can be installed and used only when the axial length of the inner bore of hub is smaller than dimension B.

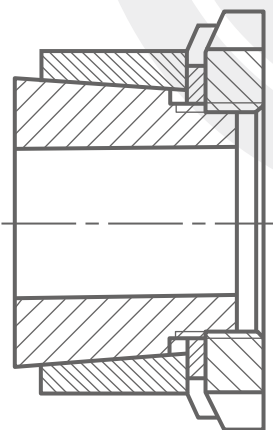

Nomenclature for CAPT-LOCK HLL

**CL 50 X 60 HLL**

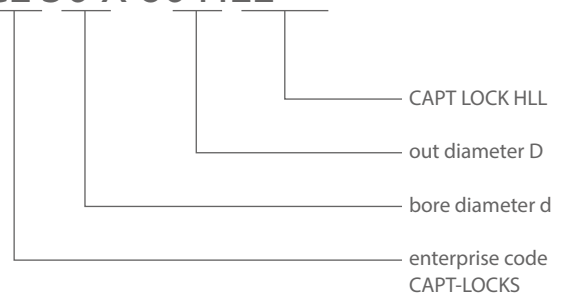

# HLL CAPT-LOCKS

# CAPT-LOCKS

# HLL

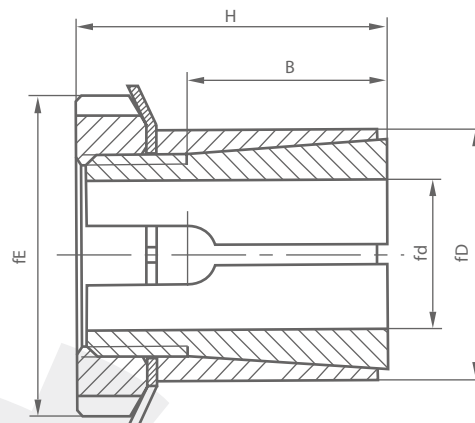

## HLL CAPT-LOCKS®

Catalog dxD	Fundamental dimensions			Locking nut		Rated load		Ps	Ph	G
	B	H	E	Sizes	Ma(N.m)	Ft(Kn)	Mt(Kn.m)	Mpa	Mpa	Kg
CL14x25HLL	20	30	32	M20x1.0	95	9	0.064	85	45	0.11
CL15x25HLL	20	30	32	M20x1.0	95	9	0.07	80	45	0.11
CL16x25HLL	20	30	32	M20x1.0	95	9	0.073	75	45	0.11
CL17x25HLL	20	32	32	M20x1.0	95	9	0.08	70	45	0.13
CL18x30HLL	20	32	38	M25x1.5	160	9	0.091	65	45	0.13
CL19x30HLL	20	32	38	M25x1.5	160	11	0.105	75	45	0.13
CL20x30HLL	20	32	38	M25x1.5	160	11	0.112	70	45	0.15
CL22x35HLL	25	36	45	M30x1.5	220	14	0.163	70	45	0.15
CL24x35HLL	25	36	45	M30x1.5	220	14	0.178	65	45	0.17
CL25x35HLL	25	36	45	M30x1.5	220	14	0.185	60	45	0.17
CL28x40HLL	30	42	52	M35x1.5	340	17	0.25	55	40	0.17
CL30x40HLL	30	42	52	M35x1.5	340	17	0.27	50	40	0.26
CL32x45HLL	30	44	58	M40x1.5	480	21	0.35	60	45	0.26
CL35x45HLL	30	44	58	M40x1.5	480	21	0.39	55	45	0.26
CL38x50HLL	30	45	65	M45x1.5	680	26	0.51	60	45	0.30
CL40x50HLL	30	45	65	M45x1.5	680	26	0.52	55	45	0.33
CL42x55HLL	30	46	70	M50x1.5	870	30	0.63	65	50	0.38
CL45x55HLL	30	46	70	M50x1.5	870	30	0.68	60	50	0.45
CL48x60HLL	30	46	75	M55x2.0	970	35	0.84	60	50	0.51
CL50x60HLL	30	46	75	M55x2.0	970	35	0.88	60	50	0.66
CL55x65HLL	30	46	80	M60x2.0	1100	37	1.03	60	50	0.72
CL60x70HLL	30	52	85	M65x2.0	1300	45	1.36	65	55	0.80



### Key elements for designing and calculation (HL-HLL)

1. Determine max torque needed and max axial load

$$M_{t \max} = \frac{30000H}{p \cdot n} \cdot K \text{ (N m)}$$

$$F_{t \max} = F_t \cdot K$$

H--Transmission power KW  
 n--rotational speed r/min  
 K--coefficient needed  
 Sheet for coefficient needed, K

No shock load, transmitting with little inertia	1.5 - 2.5
Slight shock load, transmitting with middle inertia	2.0 - 4.0
Big shock load, transmitting with heavy inertia	3.0 - 5.0

2. Calculate synthetic load and transmitted torque

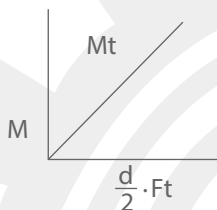
$$M = \sqrt{M_t^2 - \left(\frac{d}{2} \cdot F_t\right)^2}$$

M--Required transmitted torque N.M  
 Mt--CAPT lock rated transmitted torque N.m  
 Ft--Rated axial force N  
 d--Transmission shaft diameter mm  
 Mt ≥ M, can be used.  
 Mt < M, need bigger type of CAPT lock or to be installed by two CAPT locks or more together

3. Calculation for the hub diameter

$$D_a \geq D \sqrt{\frac{\sigma_b + K_a \cdot P_h}{\sigma_b - K_a \cdot P_h}}$$

Da--outside diameter of hub mm  
 D--inside diameter of hub mm  
 Ph--surface pressure on hub Mpa  
 σb--tensile strength of material  
 Ka--It should be 0.6 for single CAPT lock, it will be 0.8 when two CAPT locks or more are installed together

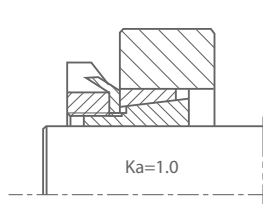
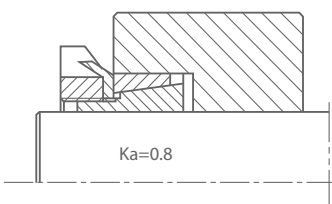

4. Calculation for the inside diameter of hollow shaft

$$d_B \leq d \sqrt{\frac{\sigma_b - 2 \times P_s \cdot K_3}{\sigma_b}}$$

dB--inside diameter of hollow shaft mm  
 d--outside diameter of hollow shaft mm  
 σb--tensile strength of shaft material Mpa  
 Ps--pressure on the surface of shaft Mpa  
 K3--coefficient=0.6

5. Settlement for the surface roughness and dimension tolerance

Fitting section	Ra(um) Surface roughness	Dimension precision
Shaft diameter d	1.6/▽	h8 - H9
Bore diameter D	1.6/▽	H8 - H9

6. Installation and disassembling for CAPT lock type HL, HLL

Installation:

Before installation, oil or dust must be cleaned up with cleaning agent so that torque transmission won't be affected. Loosen the round nut and made it in relax and meanwhile install hub, shaft and CAPT lock together in right position. But to the step shaft, a short distance "a" should be deep and data for "a" should be larger than the distance in axial while the CAPT lock is tightened. Then the round nut should be tightened in clockwise direction to reach the specified torque. At last the round nut should be locked with the washer to avoid it not to become self crowded.

Put the washers into the split groove of nuts

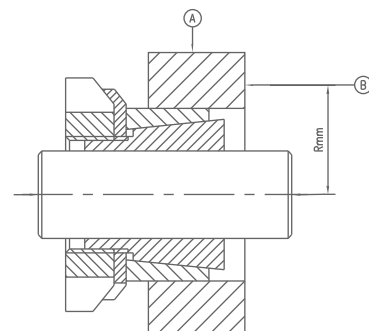
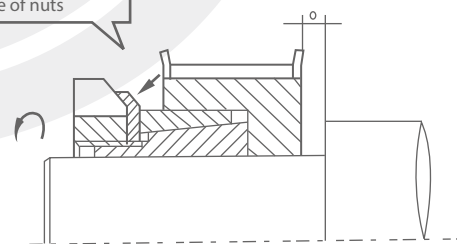

**Disassembling :**

When the disassembling is done, as long as the locked washer is opened and loose the round nut, the CAPT lock will be separated with shaft and hub, and then come back to its original shape.

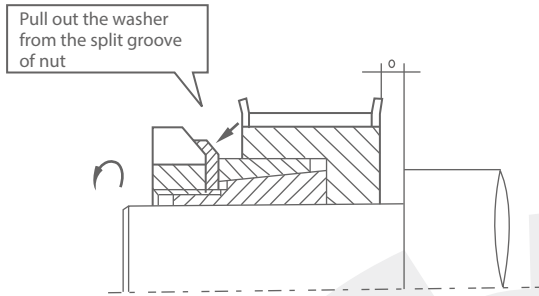

Dimension table of split round nuts

Catalog	fundamental dimensions				
	D <sub>1</sub>	b <sub>1</sub>	D	m	n
M20x1	32	6	26	4	2
M22x1	35	7	29	5	2
M25x1.5	38	7	32	5	2
M30x1.5	45	7	38	5	2
M32x1.5	48	7	41	5	2
M35x1.5	52	8	44	5	2
M36x1.5	55	9	47	6	2.5
M40x1.5	58	9	50	6	2.5
M42x1.5	62	10	52	6	2.5
M45x1.5	65	10	56	6	2.5
M48x1.5	68	11	58	6	2.5
M50x1.5	70	11	61	6	2.5
M55x2	75	11	67	7	3
M60x2	80	11	73	7	3
M65x2	85	12	79	7	3
M70x2	92	12	85	8	3.5
M75x2	98	13	90	8	3.5

Dimension table of stop backing washers

Catalog	fundamental dimensions					
	d	D	S	n	F	E
20	20.5	26	1	4	19	4
25	25.5	32	1.25	5	24	5
30	30.5	38	1.25	5	28	5
35	35.5	44	1.25	6	33	5
40	40.5	50	1.25	6	38.5	6
45	45.5	56	1.25	6	43	6
50	50.5	61	1.25	6	48	6
55	55.5	67	1.25	8	53	7
60	60.5	73	1.5	8	58.5	7
65	65.5	79	1.5	8	63	7
70	70.5	85	1.5	8	68	8
75	75.5	90	1.5	8	73	8

Conventional installation with non-through bored hubs

Conventional installation with through bored hubs

Installed pairs of CAPT-LOCKS at two sides symmetrically. They can transmit greater powers

Installed with counter bore, The CAPT-LOCKS can be completely installed into the hub, thus the installation space can be saved.

# CAPT-LOCKS

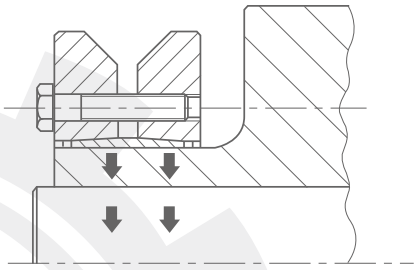
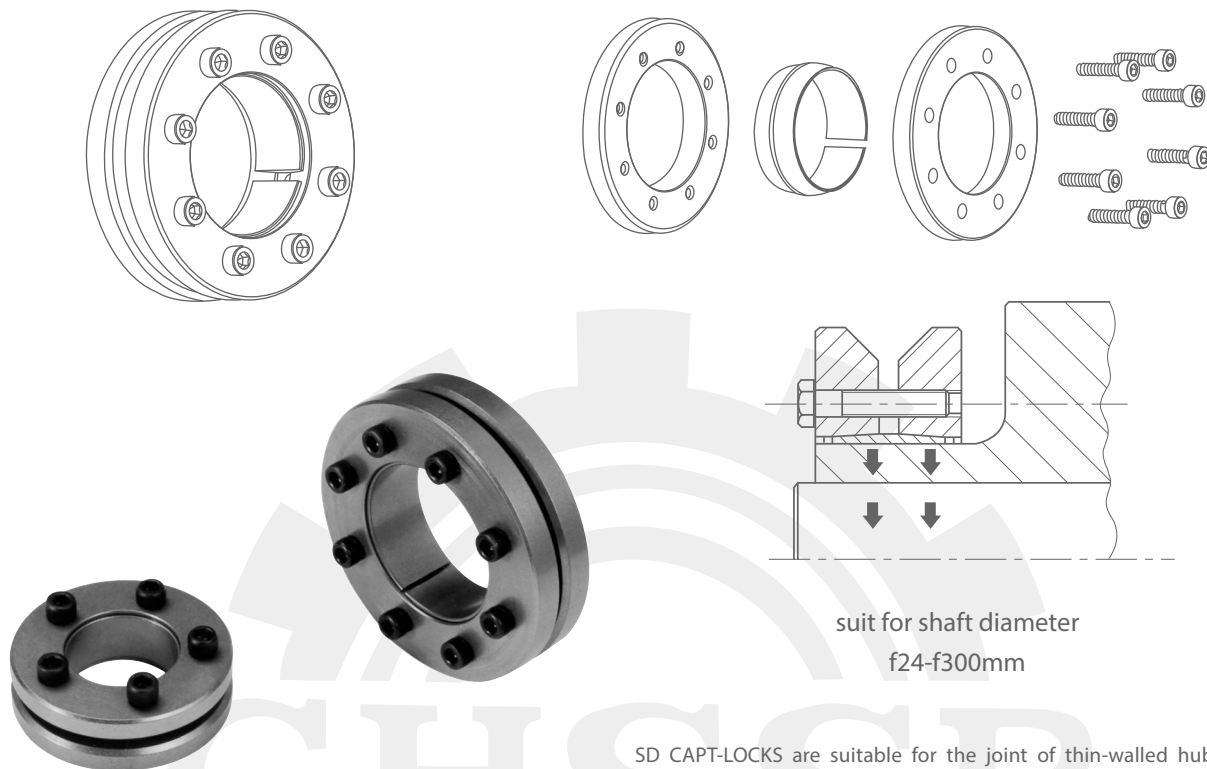

suit for shaft diameter  
f24-f300mm

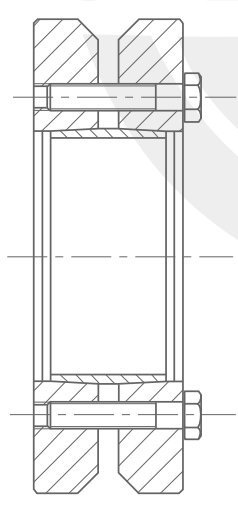

SD CAPT-LOCKS are suitable for the joint of thin-walled hubs and shafts. They have the characteristics of big shaft diameter and capability of transmitting big torque.

The working principle of SD CAPT-LOCKS is as following :

Under the pressure tightening bolts, two tightening rings with inner taper surface press the inner circle with outer taper surface and then make it contract to tighten the hubs and shafts. The emerged radial pressure and frictional force make the hubs and shafts join together.

SD CAPT-LOCKS are composed of inner circle, two taper tightening rings and the corresponding tightening bolts. Their structure is very simple, and can be installed and disassembled only with bolts,so it is very convenient to use.

### Nomenclature for CAPT-LOCKS SD

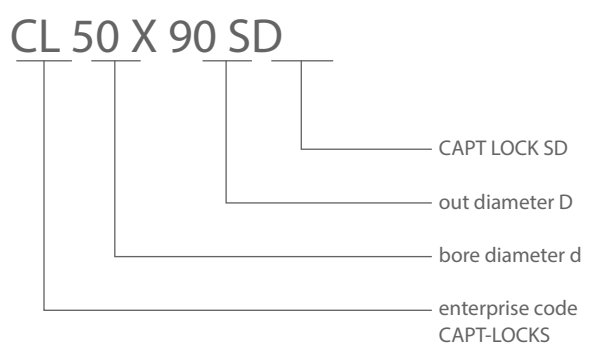

## SD CAPT-LOCKS

# CAPT-LOCKS

# SD

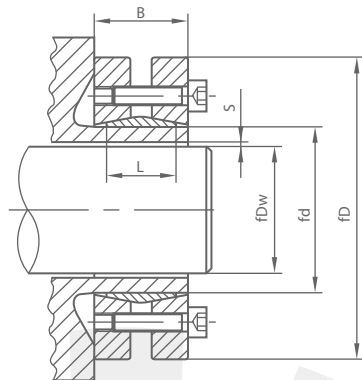

Max clearance between diameters S	DW	
	min	max
mm0.017	18	30
mm0.032	30	50
mm0.048	50	80
mm0.069	80	120
mm0.079	120	180
mm0.090	180	250
mm0.101	250	315
mm0.111	315	400
mm0.123	400	500

## SD CAPT-LOCKS®

Table:1

Catalog dxD	Fundamental dimensions			Screw bolt SizesxN	Rated load		Ps Mpa	Ph Mpa	Ma N.m	G Kg
	Dw	L	B		Ft(Kn)	Mt(Kn.m)				
CL24x50SD	19	14	19.5	M5x6	18	0.17	199	314	4.9	0.2
	20				21	0.21	216			
	21				23	0.25	232			
CL30x60SD	24	16	21.5	M5x7	20	0.25	164	254	4.9	0.3
	25				24	0.30	175			
	26				26	0.35	185			
CL36x72SD	28	18	23.5	M6x5	32	0.46	191	271	12	0.4
	30				38	0.57	210			
	31				39	0.60	204			
CL44x80SD	34	20	25.5	M6x7	46	0.78	200	278	12	0.6
	35				49	0.86	206			
	36				52	0.93	212			
CL50x90SD	38	22	27.5	M6x8	53	1.00	187	258	12	0.8
	40				59	1.18	197			
	42				65	1.36	207			
CL55x100SD	42	23	30.5	M6x8	53	1.12	165	226	12	1.1
	45				63	1.39	175			
	48				70	1.68	185			
CL62x110SD	48	23	30.5	M6x10	77	1.85	195	249	12	1.3
	50				83	2.08	202			
	52				86	2.21	200			
CL68x115SD	50	23	30.5	M6x10	72	1.78	173	229	12	1.4
	55				80	2.23	179			
	60				96	2.87	195			
CL75x138SD	55	25	32.5	M8x7	94	2.60	192	253	30	1.7
	60				111	3.31	206			
	65				126	4.12	218			
CL80x145SD	60	25	32.5	M8x7	99	2.98	185	239	30	1.9
	65				115	3.72	198			
	70				130	4.56	210			

# CAPT-LOCKS

# SD

## SD CAPT-LOCKS®

Table:2

Catalog dxD	Fundamental dimensions			SizesxN	Rated load		Ps Mpa	Ph Mpa	Ma N.m	G Kg
	Dw	L	B		Ft(Kn)	Mt(Kn.m)				
CL90x155SD	65	30	39	M8x10	140	4.61	203	255	30	3.3
	70				160	5.60	213			
	75				178	6.70	223			
CL100x170SD	70	34	44	M8x12	163	5.71	191	242	30	4.7
	75				182	6.84	200			
	80				202	8.09	208			
CL110x185SD	75	39	50	M10x9	185	6.97	178	226	59	5.9
	80				207	8.25	185			
	85				220	9.36	186			
CL125x215SD	85	42	54	M10x12	240	10.20	187	240	59	8.3
	90				262	11.80	194			
	95				285	13.50	200			
CL140x230SD	95	46	60.5	M12x10	308	14.60	196	242	100	10
	100				331	16.60	202			
	105				357	18.70	207			
CL155x265SD	105	50	64.5	M12x12	366	19.20	195	237	100	15
	110				392	21.60	200			
	115				417	24.00	203			
CL165x290SD	115	56	71	M16x8	513	29.50	222	259	250	22
	120				544	32.50	226			
	125				564	35.30	225			
CL175x300SD	125	56	71.4	M16x8	522	32.60	208	246	250	22
	130				552	35.90	212			
	135				584	39.40	215			
CL185x330SD	135	71	84	M16x10	665	45.0	194	228	250	37
	140				700	49.1	197			
	145				738	53.5	200			
CL195x350SD	140	71	86	M16x12	752	54.8	220	254	250	41
	150				860	64.6	226			
	155				900	69.8	228			
CL200x350SD	150	71	86	M16x12	860	64.6	226	254	250	41
	155				900	69.8	228			
	160				942	75.2	231			
CL220x370SD	160	88	104	M16x15	1041	83.0	206	234	250	54
	165				1080	89.2	208			
	170				1130	95.7	210			
CL240x405SD	170	92	109	M20x12	1300	111.0	233	260	490	67
	180				1400	126.0	237			
	190				1491	141.0	238			
CL260x430SD	190	103	120	M20x14	1570	149.0	224	251	490	82
	200				1690	169.0	228			
	210				1790	188.0	231			
CL280x460SD	210	114	134	M20x16	1860	196.0	218	241	490	102
	220				1990	219.0	221			
	230				2110	242.0	224			
CL330x485SD	230	122	142	M20x18	2190	251.0	217	237	490	118
	240				2310	277.0	220			
	245				2370	290.0	221			

# CAPT-LOCKS

# SS

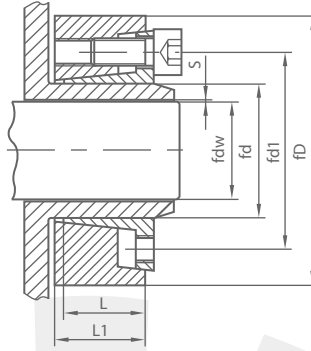

Max clearance between diameters S	DW	
	min	max
mm0.017	18	30
mm0.032	30	50
mm0.048	50	80
mm0.069	80	120
mm0.079	120	180
mm0.090	180	250
mm0.101	250	315
mm0.111	315	400
mm0.123	400	500

## SS CAPT-LOCKS®

Table:1

Catalog dxD	Fundamental dimensions				SizesxN	Rated loadPs		Ph Mpa	Ma Mpa	G N.m	Kg
	dw	L	L1	d1		Ft(Kn)	Mt(Kn.m)				
CL12x35SS	9	10	11	24	M6x3	5	0.02	780	900	12	0.1
	10					8	0.04	825			
CL14x38SS	11	10	11	26	M6x3	6	0.03	672	780	12	0.1
	12					9	0.05	712			
CL16x41SS	13	13.5	15	28	M6x3	10	0.07	430	510	12	0.1
	14					13	0.09	460			
CL18x44SS	15	13.5	15	30	M6x3	11	0.08	390	450	12	0.1
	16					14	0.11	410			
CL20x47SS	17	13.5	15	32	M6x3	18	0.15	360	400	12	0.1
	18					20	0.18	375			
CL24x50SS	19	16	18	36	M6x4	17	0.16	310	380	12	0.2
	20					20	0.21	330			
CL30x60SS	22	18	20	44	M6x6	25	0.28	360	400	12	0.2
	24					23	0.27	350			
CL36x72SS	25	20	22	52	M8x5	25	0.32	360	470	30	0.5
	26					28	0.36	370			
CL44x80SS	27	22	24	61	M8x6	32	0.44	420	420	30	0.6
	30					41	0.61	436			
CL50x90SS	33	23.5	26	68	M8x7	50	0.82	440	380	30	0.8
	34					41	0.69	351			
CL55x100SS	35	26	29	72	M8x8	44	0.77	372	375	30	1.1
	37					50	0.92	377			
CL62x110SS	38	26	29	80	M8x8	58	1.11	340	330	30	1.3
	40					65	1.29	350			
CL68x115SS	42	26	29	86	M8x9	71	1.51	360	340	30	1.3
	48					70	1.67	300			
CL75x138SS	50	27	31	100	M10x8	76	1.89	305	410	59	2.3
	52					81	2.12	310			
	50					75	1.87	295			
	55					89	2.45	310			
	60					104	3.12	325			
	65					85	2.33	365			
						101	3.02	380			
						117	3.81	390			

# CAPT-LOCKS

# SS

## SS CAPT-LOCKS<sup>®</sup>

Table:2

Catalog	Fundamental dimensions				SizesxN	Rated loadPs		Ph	Ma	G	
	dxD	dw	L	L1		d1	Ft(Kn)	Mt(Kn.m)			
CL80x141SS	60	27	31	104	M10x8	106	3.19	347	390	59	2.3
	65					123	4.06	358			
	70					140	4.91	366			
CL90x155SS	65	34	38	114	M10x10	166	5.4	315	350	59	3.2
	70					187	6.5	325			
	75					208	7.8	335			
CL100x170SS	70	39	43	124	M10x12	171	6	300	340	59	4.3
	75					192	7.2	310			
	80					213	8.5	315			
CL110x185SS	80	43.5	49	138	M12x10	249	10	280	315	100	5.8
	85					275	11.7	285			
	90					302	13.6	290			
CL120x197SS	85	46.5	53	147	M12x12	280	11.9	275	312	100	6.9
	90					307	13.8	282			
	95					334	15.9	287			
CL125x215SS	90	46.5	53	152	M12x12	319	14.4	270	310	100	8.7
	95					347	16.5	280			
	100					375	18.7	285			
CL135x230SS	95	49.5	58	165	M14x10	382	18.1	263	297	160	11
	100					412	20.6	270			
	110					473	26	275			
CL140x230SS	100	49.5	58	170	M14x10	392	19.6	260	290	160	10
	105					421	22.1	265			
	115					481	27.6	270			
CL155x263SS	110	53.5	62	184	M14x12	482	26.5	260	290	160	15
	115					514	29.5	265			
	125					578	36.1	270			
CL165x290SS	120	58	68	198	M16x10	622	37.3	245	375	250	22
	125					659	41.2	250			
	135					734	49.6	255			
CL175x300SS	130	58	68	208	M16x12	692	45	285	310	250	23
	135					730	49	290			
	145					805	58	295			
CL185x320SS	140	75	85	222	M16x14	916	64	250	270	250	33
	145					961	70	255			
	155					1053	82	260			
CL200x340SS	150	75	85	238	M16x16	1073	81	270	290	250	36
	155					1120	87	275			
	165					1216	100	280			
CL220x370SS	160	91	103	268	M20x16	1283	103	300	330	490	53
	170					1395	119	305			
	180					1509	136	310			
CL240x405SS	170	94	107	288	M20x18	1439	122	300	325	490	66
	180					1555	140	305			
	200					1790	179	310			
CL260x430SS	190	105	119	312	M20x21	1715	163	290	310	490	82
	200					1842	184	295			
	220					2099	231	300			
CL280x460SS	210	116	132	334	M20x22	2051	215	255	275	490	103
	220					2186	240	260			
	240					2458	295	265			
CL300x485SS	220	124	140	360	M24x20	2456	270	295	310	840	120
	230					2605	300	298			
	250					2906	363	300			

# CAPT-LOCKS

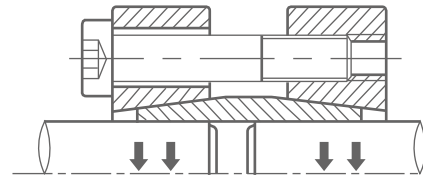
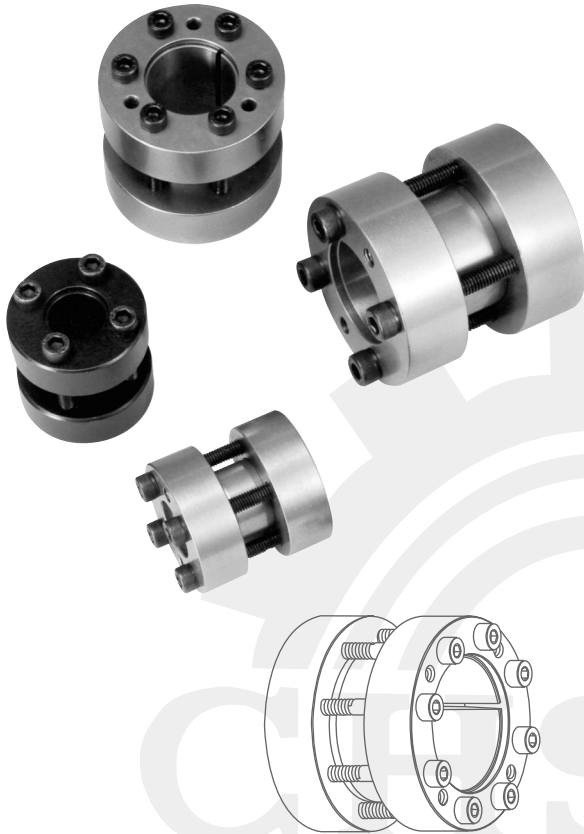

suit for shaft diameter  
f15~f110mm

SK CAPT-LOCKS are the developing types of SD CAPT-LOCKS. They are suitable for the joint between long shafts and hubs and can transmit bigger torque. They can replace couplings in some mechanical transmission if the shaft diameter and precision are the same.

The working principle of SK CAPT-LOCKS is as following: under the pressure of tightening bolts, two tightening rings with inner taper surface press the inner ring with outer taper surface and then make it contract to tighten the hubs and shafts. The emerged radial pressure and friction force make the hubs and shafts join together. SK CAPT-LOCKS are composed of one inner ring, two tightening rings with taper surface and the corresponding tightening bolts. They have the characteristics of simple structure, easy on and easy off with the corresponding tightening bolts, low costs and easy to use.

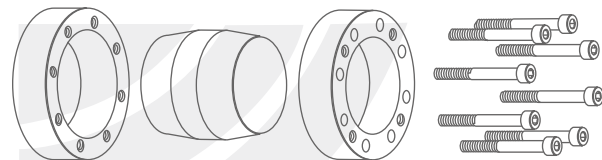
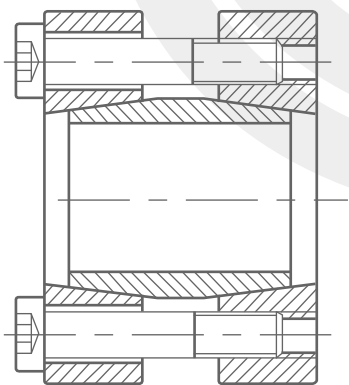

Nomenclature for CAPT-LOCK SK

**CL 50 X 60 SK**

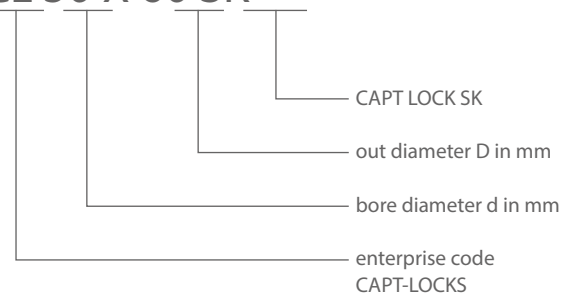

**SK** CAPT-LOCKS



# CAPT-LOCKS

# SK

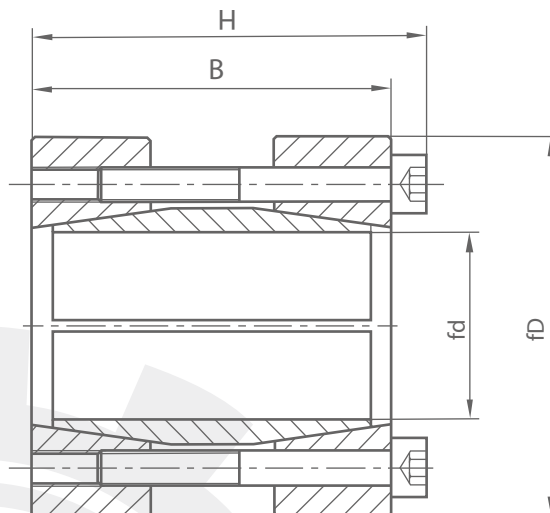

## SK CAPT-LOCKS®

Catalog	Fundamental dimensions		SizesxN	Rated load		Ps	Ma	G
	B	H		Ft(Kn)	Mt(Kn.m)	Mpa	N.m	Kg
CL15x45SK	50	56	M6x4	16.8	0.126	127	17	0.4
CL16x45SK	50	56	M6x4	16.8	0.134	119	17	0.4
CL17x45SK	50	56	M6x4	16.8	0.142	112	17	0.4
CL18x50SK	50	56	M6x4	16.8	0.151	105	17	0.5
CL19x50SK	50	56	M6x4	16.8	0.159	100	17	0.5
CL20x50SK	50	56	M6x4	16.8	0.168	95	17	0.5
CL22x55SK	60	66	M6x4	25.2	0.277	103	17	0.7
CL24x55SK	60	66	M6x4	25.2	0.302	95	17	0.73
CL25x55SK	60	66	M6x6	25.2	0.315	91	17	0.77
CL28x60SK	60	66	M6x6	25.2	0.327	87	17	0.91
CL30x60SK	60	66	M6x6	25.2	0.352	81	17	0.81
CL32x65SK	60	66	M6x6	31.2	0.378	76	17	0.80
CL35x75SK	75	83	M8x4	31.2	0.499	80	42	1.30
CL38x75SK	75	83	M8x4	31.2	0.546	73	42	1.20
CL40x75SK	75	83	M8x4	31.2	0.592	67	42	1.40
CL42x78SK	75	83	M8x4	31.2	0.624	64	42	1.33
CL45x85SK	85	93	M8x6	46.8	0.982	74	42	2.30
CL48x90SK	85	93	M8x6	46.8	1.053	69	42	2.30
CL50x90SK	85	93	M8x6	46.8	1.123	65	42	2.50
CL55x95SK	85	93	M8x8	62.4	1.17	62	42	2.40
CL60x100SK	85	93	M8x8	62.4	1.71	58	42	3.00
CL65x105SK	85	93	M8x8	62.4	1.87	53	42	3.30
CL70x115SK	100	110	M10x6	62.4	2.02	49	84	4.10
CL75x120SK	100	110	M10x6	91	2.12	47	84	3.80
CL80x125SK	100	110	M10x8	98.4	3.44	66	84	5.20
CL85x130SK	100	110	M10x8	123	3.69	62	84	5.50
CL90x135SK	100	110	M10x8	123	4.92	73	84	7.00
CL95x140SK	120	132	M10x8	123	5.22	68	84	7.50
CL100x150SK	120	132	M12x8	144	5.53	65	145	7.80
CL105x155SK	120	132	M12x8	144	5.84	57	145	7.90
CL110x160SK	120	132	M12x8	180	7.20	65	145	10.4

### Key elements for designing and calculation:

1. Determine max torque needed and max axial load

$$M_{t \max} = \frac{30000H}{p \cdot n} \cdot K \text{ (N m)}$$

$$F_{t \max} = F_t \cdot K$$

H--Transmission power KW

n--rotational speed r/min

K--coefficient needed

Sheet for coefficient needed, K

No shock load, transmitting with little inertia	1.5 - 2.5
Slight shock load, transmitting with middle inertia	2.0 - 4.0
Big shock load, transmitting with heavy inertia	3.0 - 5.0

2. Calculate synthetic load and transmitted torque

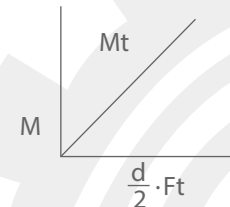
$$M = \sqrt{M_t^2 - \left(\frac{d}{2} \cdot F_t\right)^2}$$

M--Required transmitted torque N.M

Mt--CAPT lock rated transmitted torque N.m

Ft--Rated axial force N

d--Transmission shaft diameter mm

Mt ≥ M, can be used.

Mt < M, need bigger type of CAPT lock or to be installed by two CAPT locks or more together

3. Determine the surface roughness and dimension tolerance

$$D_a \geq D \sqrt{\frac{\sigma_b + K_a \cdot P_h}{\sigma_b - K_a \cdot P_h}}$$

Da--outside diameter of hub mm

D--inside diameter of hub mm

Ph--surface pressure on hub Mpa

σb--tensile strength of material

Ka--It should be 0.6 for single CAPT lock, it will be 0.8 when two CAPT locks or more are installed together

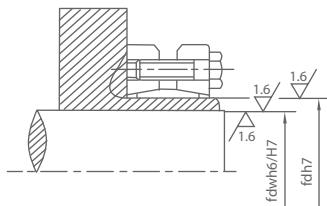

Fitting section	Ra(um) Surface roughness	Dimension precision
Shaft diameter d	1.6/√	h8 - H9
Bore diameter D	1.6/√	H8 - H9

4. Installation and disassembling for SD & SK type CAPT lock.

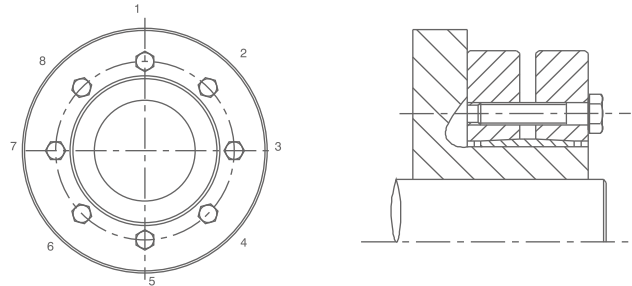

1. Clean the CAPT locks, hubs and shafts before installation. compose the CAPT LOCKS with hub and shaft, adjust it to suitable position for installation.

2. Install the tightening bolts into the corresponding tap bores and twist them according to the drawing in proper order. The bolts should be tightened by giving more and more force step by step in several times until up to the rated torque. Torque spanner have to be used to twist tightening bolts in order to ensure the rated torque.

3. Loose and remove all the tightening bolts in order to ensure the CAPT LOCKS disassemble properly.

5. Attention to the designing for hub structure.

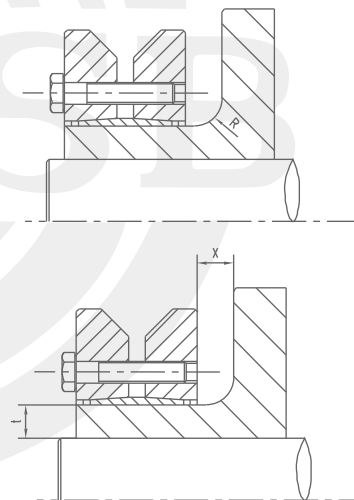

In order to ensure the hubs with enough strength, the interim radius must be bigger than 6mm, the distance X between the face of CAPT lock and the face of hubs must be bigger than R, and also should meet X.t.

6. Operation attention

1. The actual torque will be reduced 10% due to the jointed shafts with deway.

2. SD and SK type Capt Locks should work under temperature from -30 °C to +200 °C.

3. Pay attention to anti-rust, avoid to influence life time and affect disassembling when used outside.

4. Please do not exchange tightening bolts. Please contact with seller to exchange if they were damaged.